

PART REV	DWG ISSUE	DATE	ECN NO.	APPVD BY	REL BY
-	-	3-23-12	UMI 4590		

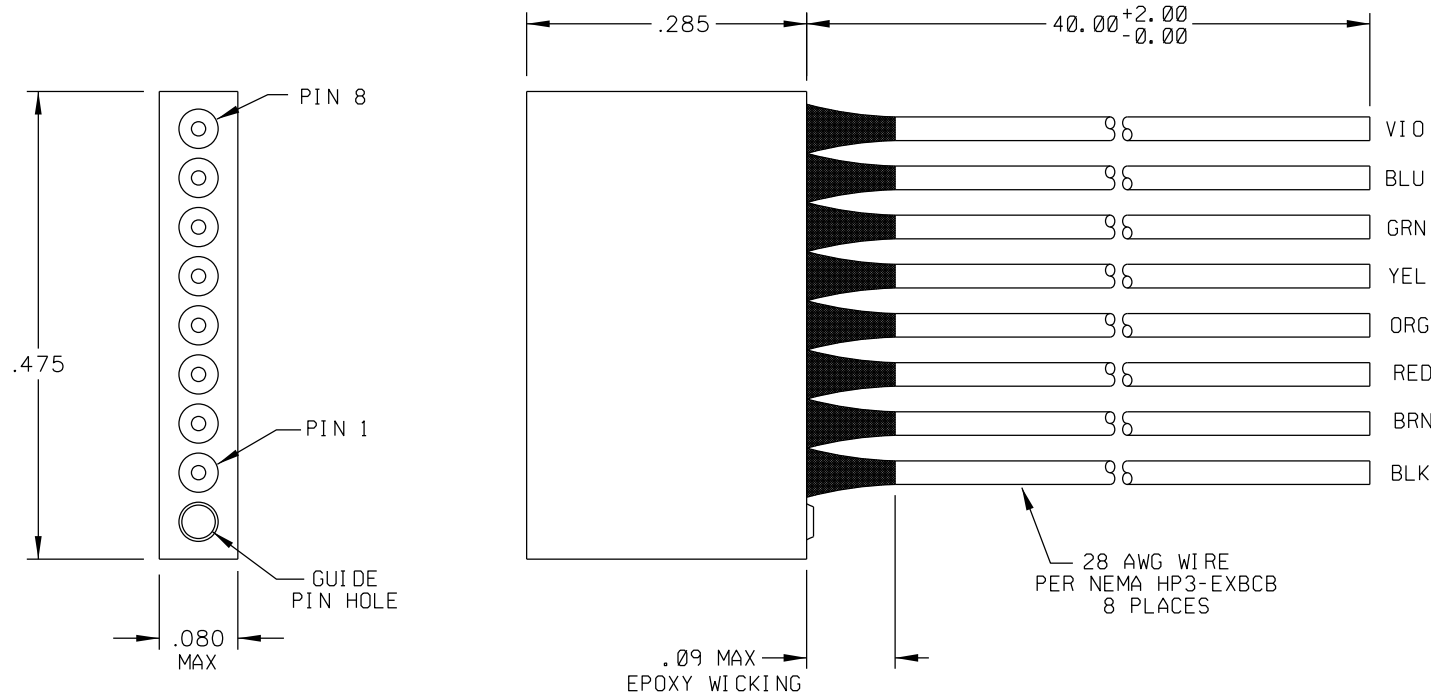

- 2 MATERIALS:
 INSULATOR: PPS PER MIL-M-24519 GST-40F, COLOR: BLACK
 PIN CONTACTS: C17200 BERYLLIUM COPPER PER ASTM B194,
 GOLD PLATED PER ASTM B488
1. MARKING: UMI DATE CODE, UMI PART NUMBER, AND "UMI" (AS SPACE PERMITS)
- NOTES: UNLESS OTHERWISE SPECIFIED.

QUALITY SYMBOLS MAJOR CRITICAL SPC	UNLESS SPECIFIED: ALL DIMENSIONS IN INCHES	SCALE 8:1	DWG SIZE B	THIRD ANGLE PROJECTION	REVISE ON CAD ONLY
	GENERAL TOLERANCES: 3 PLACE ±.005 2 PLACE ±.01 ANGULAR ±2°	DRAWN BY & DATE DW 3-23-12	TITLE: STRIP CONNECTOR, MALE, SIZE 8, 28 AWG LEADS, GUIDE PIN, SR08P1-28E5-40.0		
	Uti-Mate CAGE CODE 58967	CHECKED BY & DATE	MATERIAL: 2		Uti-Mate Connector Inc.
		APPROVED BY & DATE	CAD FILENAME SD-837081 911.DGN	PART NO. 837081 911	DRAWING NO. SD-837081 911
		THIS DRAWING CONTAINS INFORMATION THAT IS PROPRIETARY TO ULTI-MATE INCORPORATED AND SHOULD NOT BE USED WITHOUT WRITTEN PERMISSION.			REV -