

PART REV	DWG ISSUE	DATE	ECN NO.	APPVD BY	REL BY
-	-	11-18-10	UMI 4224	DW	DW

1	BLK	34	ORG	67	BLU
2	BRN	35	YEL	68	VIO
3	RED	36	GRN	69	GRY
4	ORG	37	BLU	70	WHT
5	YEL	38	BLU	71	BLK
6	GRN	39	GRY	72	BRN
7	BLU	40	WHT	73	RED
8	VIO	41	BLK	74	ORG
9	GRY	42	BRN	75	YEL
10	WHT	43	RED	76	GRN
11	BLK	44	ORG	77	BLU
12	BRN	45	YEL	78	VIO
13	RED	46	GRN	79	GRY
14	ORG	47	BLU	80	WHT
15	YEL	48	VIO	81	BLK
16	GRN	49	GRY	82	BRN
17	BLU	50	WHT	83	RED
18	VIO	51	BLK	84	ORG
19	GRY	52	BRN	85	YEL
20	WHT	53	RED	86	GRN
21	BLK	54	ORG	87	BLU
22	BRN	55	YEL	88	VIO
23	RED	56	GRN	89	GRY
24	ORG	57	BLU	90	WHT
25	YEL	58	VIO	91	BLK
26	GRN	59	GRY	92	BRN
27	BLU	60	WHT	93	RED
28	VIO	61	BLK	94	ORG
29	GRY	62	BRN	95	YEL
30	WHT	63	RED	96	GRN
31	BLK	64	ORG	97	BLU
32	BRN	65	YEL	98	VIO
33	RED	66	GRN	99	GRY
				100	WHT

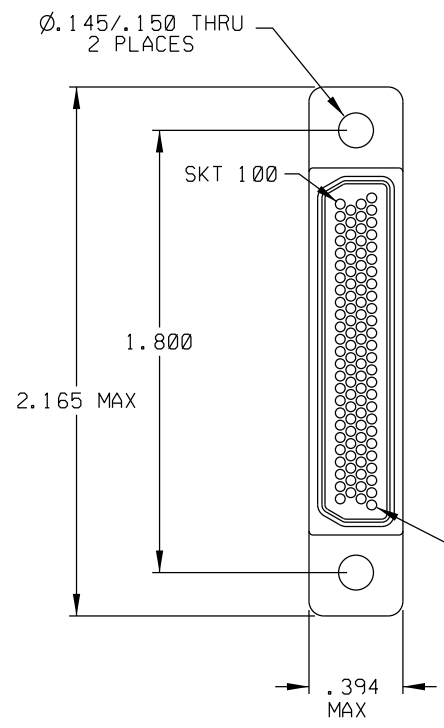

SKT 1 TO BE MARKED WITH A DOT AT LOCATION SHOWN

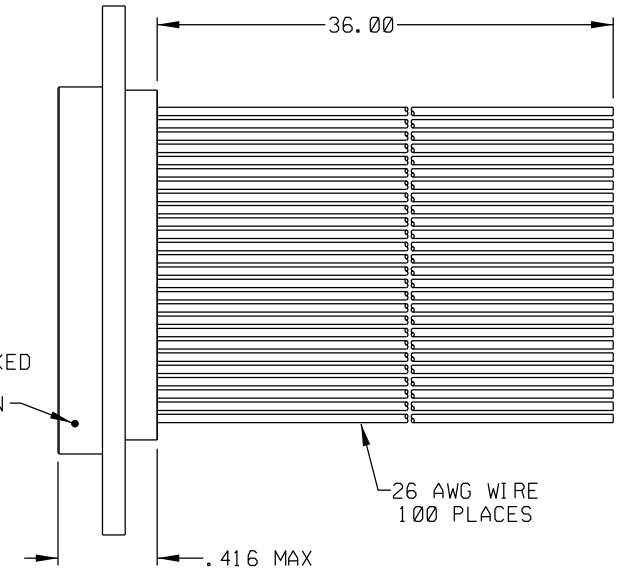

PART NUMBER	MIL-SPEC P/N	SHELL PLATING	PLATING STANDARD
835280120	M83513/04-H12C	CADMIUM	SAE AMS-QQ-P-416
835281120	M83513/04-H12N	ELECTROLESS NICKEL	AMS 2404

2 MATERIALS:
 SHELL: 6061-T6 ALUMINUM PER QQ-A200/8, SEE CHART FOR PLATING OPTIONS
 INSULATOR: PPS PER MIL-M-24519 GST-40F
 SOCKET CONTACTS: CDA210 COPPER ALLOY, GOLD PLATED PER ASTM B488
 INTERFACIAL SEAL PER MIL-R-25988
 WIRE: PER M22759/33-26; COLOR CODED PER M83513/4 (10 SOLID COLORS REPEATING - NO STRIPES)
 1. MARKINGS: "UMI", UMI DATE CODE, MIL SPEC PART NO. SHOWN ABOVE AND POSITION 1 TO BE MARKED AT LOCATION SHOWN ABOVE
 NOTES: UNLESS OTHERWISE SPECIFIED

QUALITY SYMBOLS CRITICAL SPECIAL KEY	UNLESS SPECIFIED: ALL DIMENSIONS IN INCHES GENERAL TOLERANCES: 3 PLACE ±.002 2 PLACE ±.005 ANGULAR ±2°	SCALE: 2:1 DWG SIZE: B	THIRD ANGLE PROJECTION REVISE ON CAD ONLY	
	ALL EXTERNAL SPECIFICATIONS REFERENCED ON THIS DRAWING SHALL BE TO THE LATEST REVISION IN EFFECT Uti-Mate CAGE CODE: 58967	DRAWN BY & DATE: DW 11-18-10 CHECKED BY & DATE: SEE ECN APPROVED BY & DATE: SEE ECN	TITLE: MICRO-D RECEPTACLE, WIRED, SOCKET CONTACTS, SIZE 100, MATERIAL: 2	
		CAD FILENAME: SD-835280120.DGN PART NO.: SEE CHART DRAWING NO.: SD-835280120	SHEET NO.: 1 OF 1 PART REV: -	
	THIS DRAWING CONTAINS INFORMATION THAT IS PROPRIETARY TO ULTI-MATE INCORPORATED AND SHOULD NOT BE USED WITHOUT WRITTEN PERMISSION.			

