

PART REV	DWG ISSUE	DATE	ECN NO.	APPVD BY	REL BY
-	-	5-8-14	UMI 5309	DW	DW

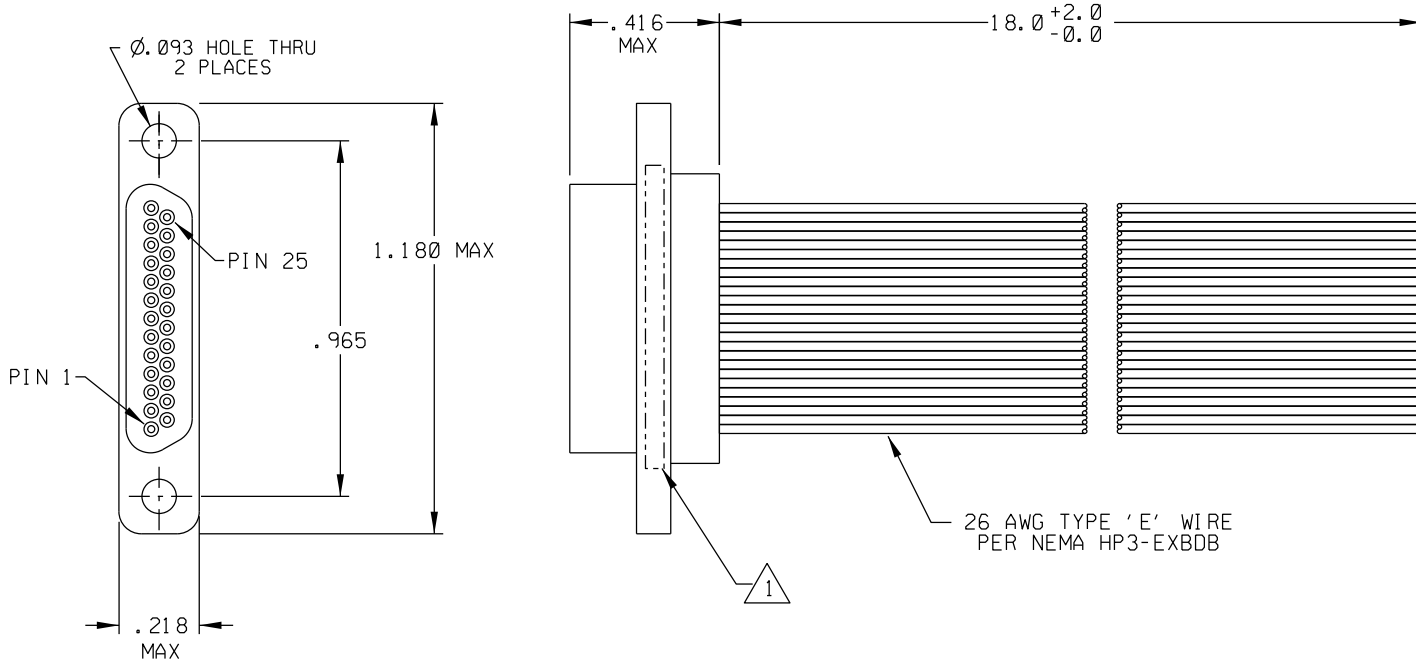

1	BLK
2	BRN
3	RED
4	ORG
5	YEL
6	GRN
7	BLU
8	VIO
9	GRY
10	WHT
11	W/BLK
12	W/BRN
13	W/RED
14	W/ORG
15	W/YEL
16	W/GRN
17	W/BLU
18	W/VIO
19	W/GRY
20	W/BLK/BRN
21	W/BLK/RED
22	W/BLK/ORG
23	W/BLK/YEL
24	W/BLK/GRN
25	W/BLK/BLU

3. PERFORMANCE SPECIFICATIONS:
 CURRENT RATING: 3 AMPS MAX
 INSULATION RESISTANCE: 5000 MEGOHMS MIN.
 DWV: 600 VAC;
 TEMPERATURE RATING: 125°C

2 MATERIALS:
 BODY/INSULATOR: PPS PER MIL-M-24519 GST-40F, COLOR: BLACK
 PIN CONTACTS: C17200 BERYLLIUM COPPER PER ASTM B194,
 GOLD PLATED PER ASTM B488

1 MARKINGS: UMI, UMI PART NO., AND DATE CODE

NOTES: UNLESS OTHERWISE SPECIFIED

QUALITY SYMBOLS CRITICAL SPECIAL KEY	UNLESS SPECIFIED: ALL DIMENSIONS IN INCHES GENERAL TOLERANCES: 3 PLACE ±.005 2 PLACE ±.01 ANGULAR ±2°	SCALE 3:1	DWG SIZE B	THIRD ANGLE PROJECTION	REVISE ON CAD ONLY	
	ALL EXTERNAL SPECIFICATIONS REFERENCED ON THIS DRAWING SHALL BE TO THE LATEST REVISION IN EFFECT Ulti-Mate CAGE CODE 58967	DRAWN BY & DATE DW 5-8-14	TITLE: MICRO-D PLUG, SIZE 25, LOW PROFILE PLASTIC SHELL, PR25P0-26E5-18.0		MATERIAL: 2 Ulti-Mate Connector Inc.	
		CHECKED BY & DATE SEE ECN	APPROVED BY & DATE SEE ECN	CAD FILENAME SD-834548070.DGN		PART NO. 834548070
	THIS DRAWING CONTAINS INFORMATION THAT IS PROPRIETARY TO ULTI-MATE INCORPORATED AND SHOULD NOT BE USED WITHOUT WRITTEN PERMISSION.		PART REV -			