

PART REV	DWG ISSUE	DATE	ECN NO.	APPVD BY	REL BY
-	-	1-20-14	UMI 5208	DW	DW

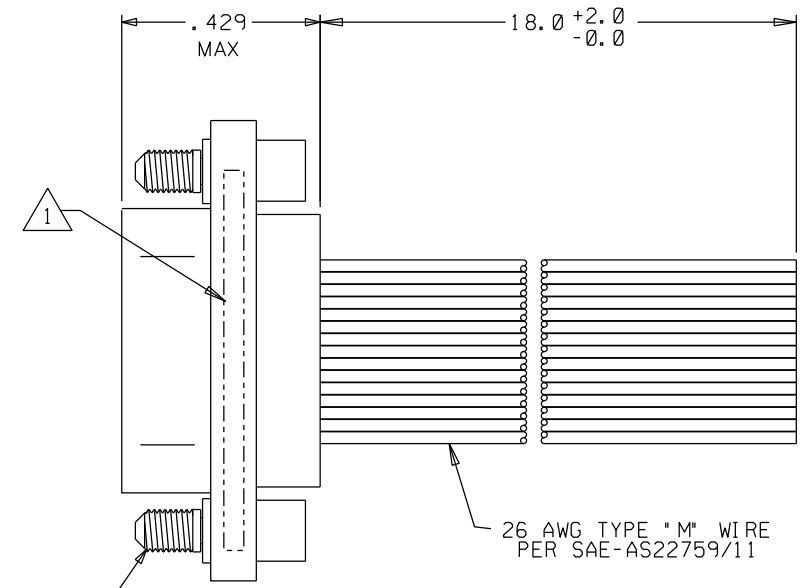
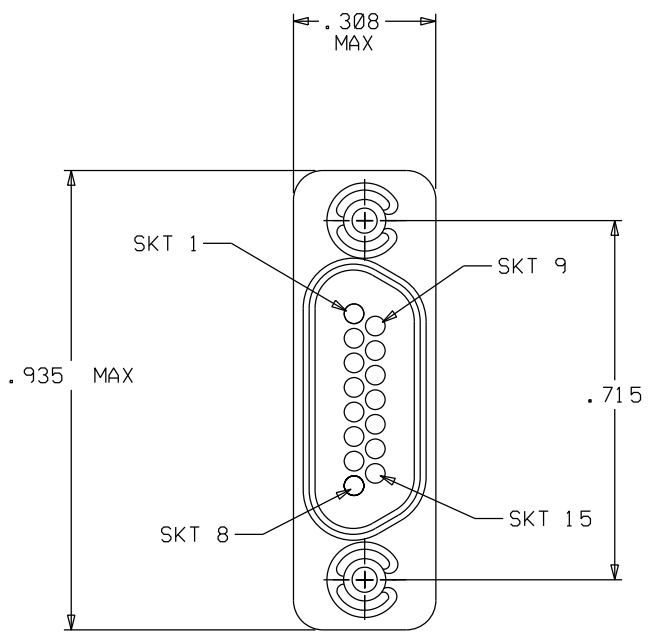

SKT	
1	BLK
2	BRN
3	RED
4	ORG
5	YEL
6	GRN
7	BLU
8	VIO
9	GRY
10	WHT
11	W/BLK
12	W/BRN
13	W/RED
14	W/ORG
15	W/YEL

2-56 JACKSCREW,
LOW PROFILE ALLEN HEAD
2 PLACES

3. PERFORMANCE SPECIFICATIONS:
CURRENT RATING: 3A MAX
INSULATION RESISTANCE: 5000 MEGOHMS MIN
DWV: 600 VAC
TEMPERATURE RATING: 200°C

2 MATERIALS:
SHELL: 6061-T6 ALUMINUM PER QQ-A200/8 NICKEL PLATED PER AMS 2404
INSULATOR: PPS PER MIL-M-24519 GST-40F, COLOR: BLACK
SOCKET CONTACT: C21000 BRASS ALLOY, 1/2 HARD, PER ASTM B36
GOLD PLATED PER ASTM B488
HARDWARE: PASSIVATED STAINLESS STEEL IAW MIL-DTL-83513/5
INTERFACIAL SEAL: FLUROSILICONE PER MIL-R-25988

1 MARKING: UMI, DATE CODE, UMI P/N.

NOTES: UNLESS OTHERWISE SPECIFIED.

QUALITY SYMBOLS CRITICAL MAJOR NO SYMBOL - MINOR DIMENSION	UNLESS SPECIFIED: ALL DIMENSIONS IN INCHES GENERAL TOLERANCES: 3 PLACE ±.005 2 PLACE ±.01 ANGULAR ±2°	SCALE: NONE DWG SIZE: B THIRDS ANGLE PROJECTION	REVISE ON CAD ONLY		
	ALL EXTERNAL SPECIFICATIONS REFERENCED ON THIS DRAWING SHALL BE TO THE LATEST REVISION IN EFFECT UMI-Mate CAGE CODE 58967	DRAWN BY & DATE: DW 1-20-14 CHECKED BY & DATE: SEE ECN APPROVED BY & DATE: SEE ECN	TITLE: RECEPTACLE ASSEMBLY, 15 POSITION, 26 AWG 18" LEADS, MRI 5S02-26M5-18.0-S01-HT		MATERIAL: 2
		CAD FILENAME: SD-434221182.DGN PART NO.: 434221182 DRAWING NO.: SD-434221182	SHEET NO.: 1 OF 1	Uti-Mate Connector Inc.	
		THIS DRAWING CONTAINS INFORMATION THAT IS PROPRIETARY TO ULTI-MATE INCORPORATED AND SHOULD NOT BE USED WITHOUT WRITTEN PERMISSION.			