

10

9

8

7

6

5

4

3

2

SD-837041041

PART REV	DWG ISSUE	DATE	ECN NO.	APPVD BY	REL BY
-	-	8/23/21	UMI7832	DU	DW

F

E

D

C

B

A

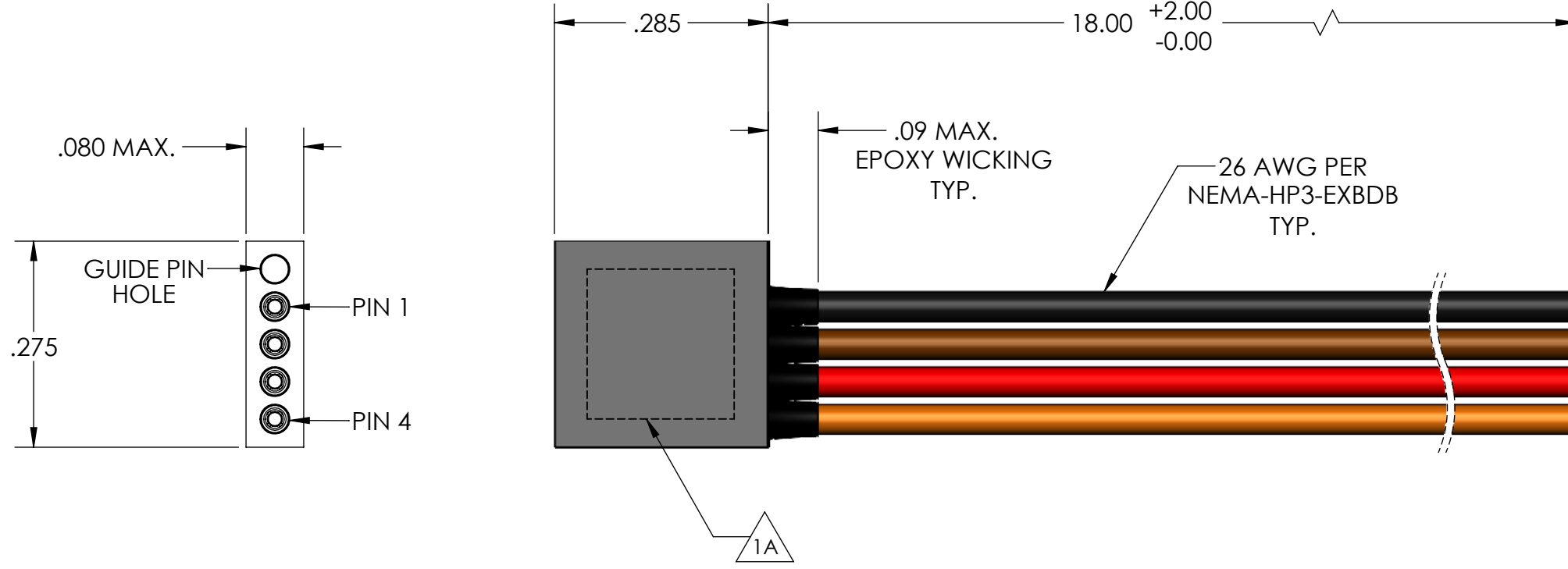

GUIDE PIN HOLE	
1	BLK
2	BRN
3	RED
4	ORG



- 5. CONTACT HEIGHTS ARE TO BE PER QA-STD-101.
- 4. PERFORMANCE SPECIFICATIONS:
 CURRENT RATING: 3 AMPS MAX.
 INSULATION RESISTANCE: 5000 MEGOHMS MIN.
 DWV: 600 VAC
 TEMPERATURE RATING: -55°C TO 125°C

2 MATERIALS:
 INSULATOR: PPS PER MIL-M-24519 GST-40F, COLOR: BLACK
 PIN CONTACTS: C17200 BERYLLIUM COPPER PER ASTM B194, GOLD PLATED PER ASTM B488
 WIRES: 26 AWG PER NEMA-HP3-EXBDB, COLOR CODE PER MIL-STD-681

- 1. MARKING: 1A UMI WORK ORDER NUMBER
 1B BAG AND TAG WITH "UMI", DATE CODE, UMI PART NUMBER.

NOTES: UNLESS OTHERWISE SPECIFIED.

QUALITY SYMBOLS CRITICAL C MAJOR NO SYMBOLS = MINOR DIMENSIONS	UNLESS OTHERWISE SPECIFIED; ALL DIMENSIONS ARE IN INCHES	SCALE 4:1	DWG SIZE B	THIRD ANGLE PROJECTION	REVISE ON CAD ONLY	
	GENERAL TOLERANCES: 3 PLACES ±.005 2 PLACES ±.01 ANGULAR ±2°	DRAWN BY & DATE DU 8/23/21		TITLE: MICRO STRIP CONNECTOR, SR04P1-26E5-18.00		
		CHECKED BY & DATE DW 8/23/21		MATERIAL: 2	ENG PROJECT #: NONE	
		APPROVED BY & DATE DW 8/23/21		PART NO. 837041041		DRAWING NO. SD-837041041
	ULTI-MATE CAGE CODE 58967		CAD FILE NAME SD-837041041.slddrw		SHEET NO. 1 of 1	
THIS DRAWING CONTAINS INFORMATION THAT IS PROPRIETARY TO ULTI-MATE INCORPORATED AND SHOULD NOT BE USED WITHOUT WRITTEN PERMISSION.						

