

10

9

8

7

6

5

4

3

2

SD-836280617

REVISIONS					
PART REV.	DWG. ISSUE	DATE	ECN NO.	APPVD. BY	REL. BY
-	-	3/19/2021	UMI7707	DU	DW

F

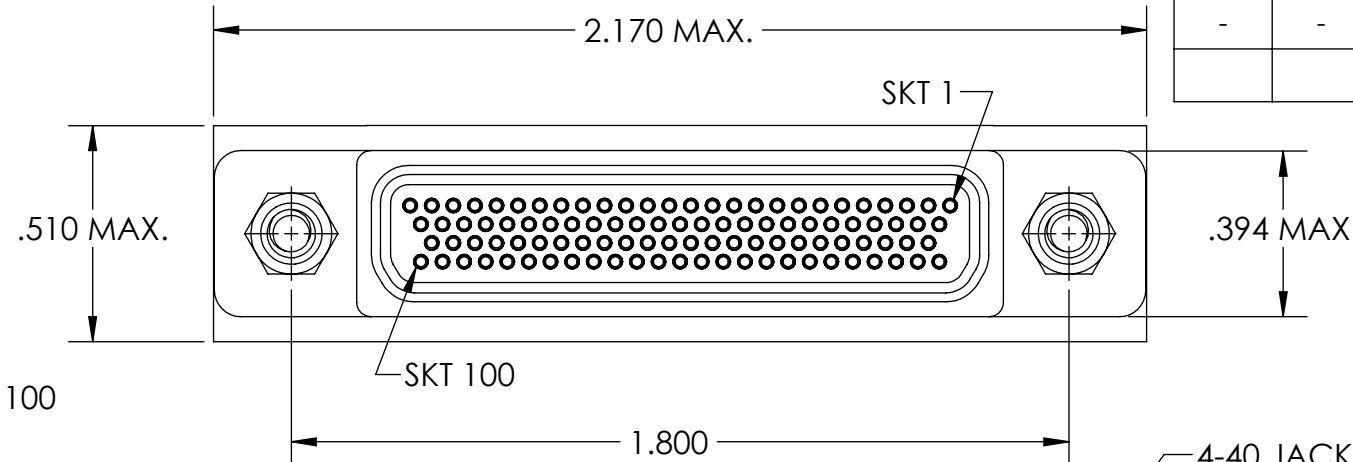
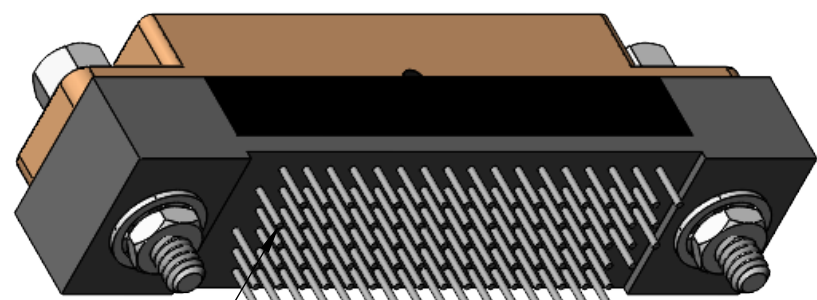

E

POSITION 1 ↓ PCB VIEW POSITION 100

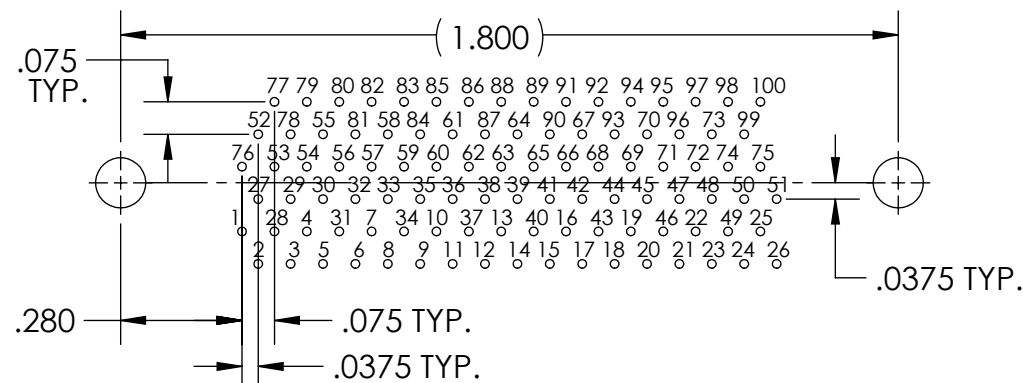

RECOMMENDED PCB LAYOUT

D

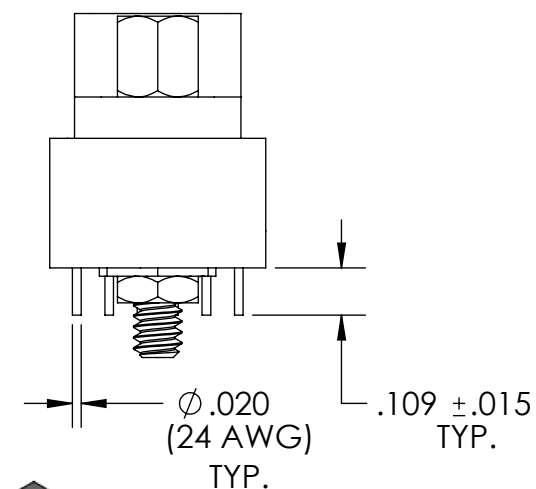
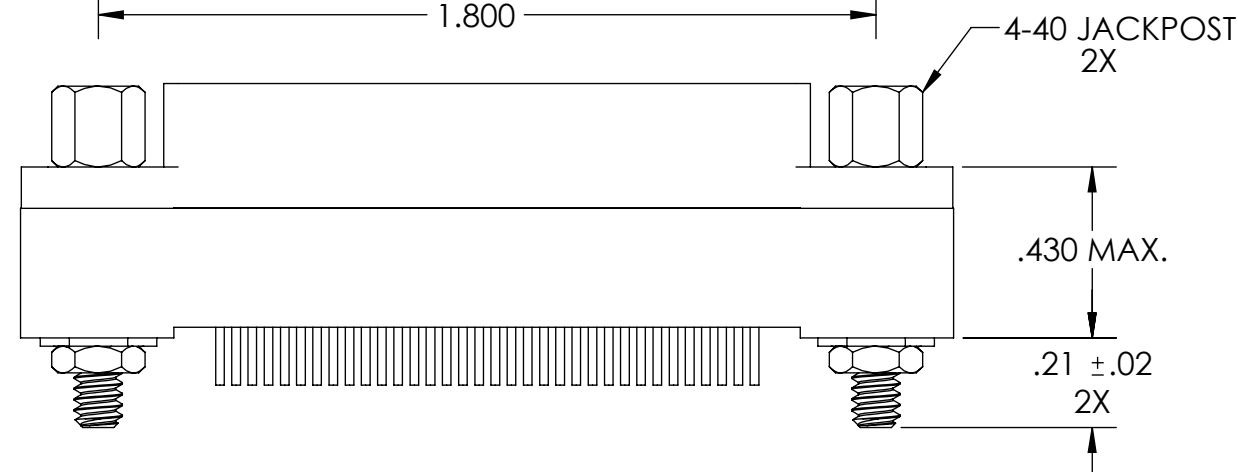

C

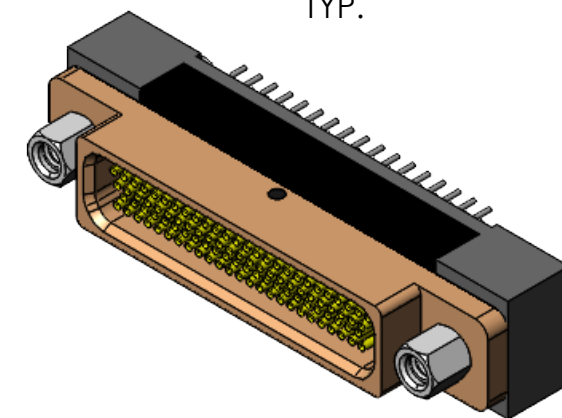
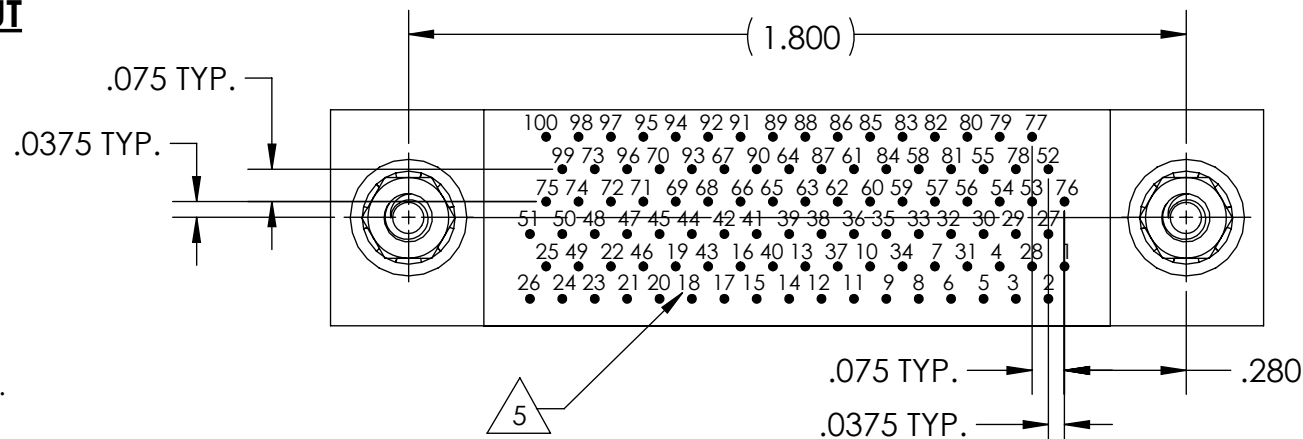

6. CONTACT HEIGHTS ARE TO BE PER QA-STD-101.

5 NUMBERS, (LEAD LOCATIONS), ARE SHOWN FOR REFERENCE ONLY AND DO NOT APPEAR ON ACTUAL PART.

4. PERFORMANCE SPECIFICATIONS:
 CURRENT RATING: 3 AMP MAX.
 DWV: 600 VAC
 TEMPERATURE RATING: -55°C TO 125°C

3 MATERIALS:
 SHELL: 6061-T6 ALUMINUM PER AMS-QQ-A200/8, CADMIUM PLATED PER AMS-QQ-P-416
 INSULATOR/BACKSHELL: PPS PER MIL-M-24519 GST-40F, COLOR: BLACK
 SOCKET CONTACTS: C21000 COPPER ALLOY PER ASTM B36, GOLD PLATED PER ASTM B488
 24 AWG LEADS: TIN PLATED COPPER ALLOY PER A-A-59551, TYPE S
 HARDWARE: PASSIVATED STAINLESS STEEL, 300 SERIES
 INTERFACIAL SEAL: FLUOROSILICONE PER MIL-R-25988

2. MARKING: "UMI", DATE CODE, UMI PART NUMBER, UMI WORK ORDER NUMBER

1. CONNECTOR ASSEMBLY IS IAW MIL-DTL-83513 WHERE APPLICABLE.

NOTES: UNLESS OTHERWISE SPECIFIED.

QUALITY SYMBOLS CRITICAL MAJOR NO SYMBOLS = MINOR DIMENSIONS	UNLESS OTHERWISE SPECIFIED: ALL DIMENSIONS ARE IN INCHES	SCALE 2 : 1	DWG SIZE B	THIRD ANGLE PROJECTION	REVISE ON CAD ONLY	
	GENERAL TOLERANCES: 3 PLACES ±.005 2 PLACES ±.01 ANGULAR ±2°	DRAWN BY & DATE DU 3/19/21	TITLE: MICRO-D CIRCUIT CONNECTOR, CM6R100S17, CADMIUM PLATED SHELL			
	ULTI-MATE CAGE CODE 58967	CHECKED BY & DATE DW 3/19/21	MATERIAL: 3		ENG PROJECT #: NONE	
		APPROVED BY & DATE DW 3/19/21	PART NO. 836280617	DRAWING NO. SD-836280617	SHEET NO. 1 of 1	
		CAD FILE NAME SD-836280617.slddrw	THIS DRAWING CONTAINS INFORMATION THAT IS PROPRIETARY TO ULTI-MATE INCORPORATED AND SHOULD NOT BE USED WITHOUT WRITTEN PERMISSION.			