

REVISIONS					
PART REV.	DWG. ISSUE	DATE	ECN NO.	APPVD. BY	REL. BY
-	-	9/14/2021	UMI7853	DU	DW

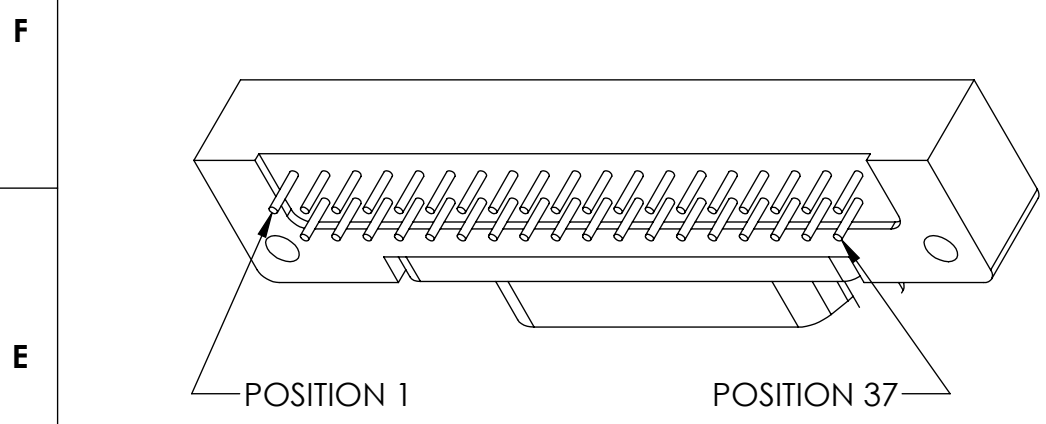

PCB VIEW

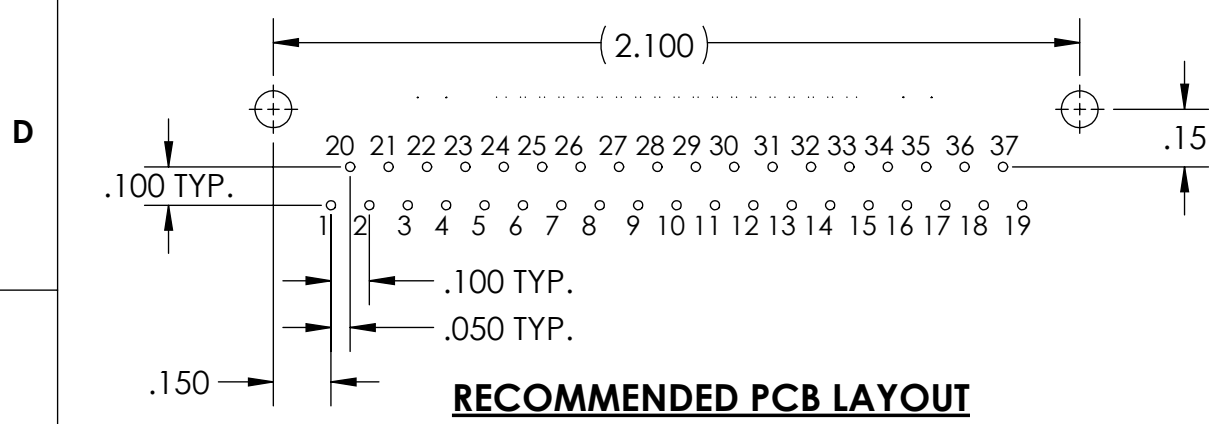

RECOMMENDED PCB LAYOUT

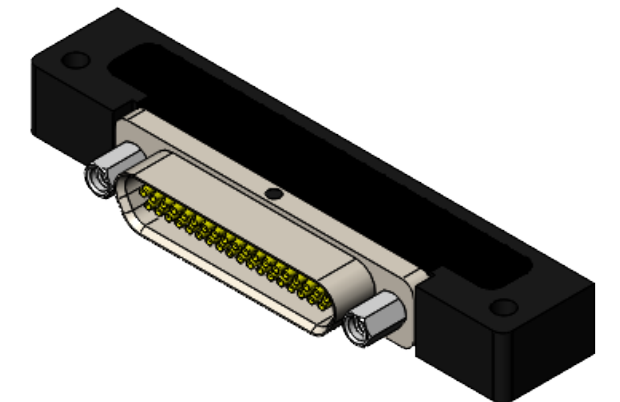
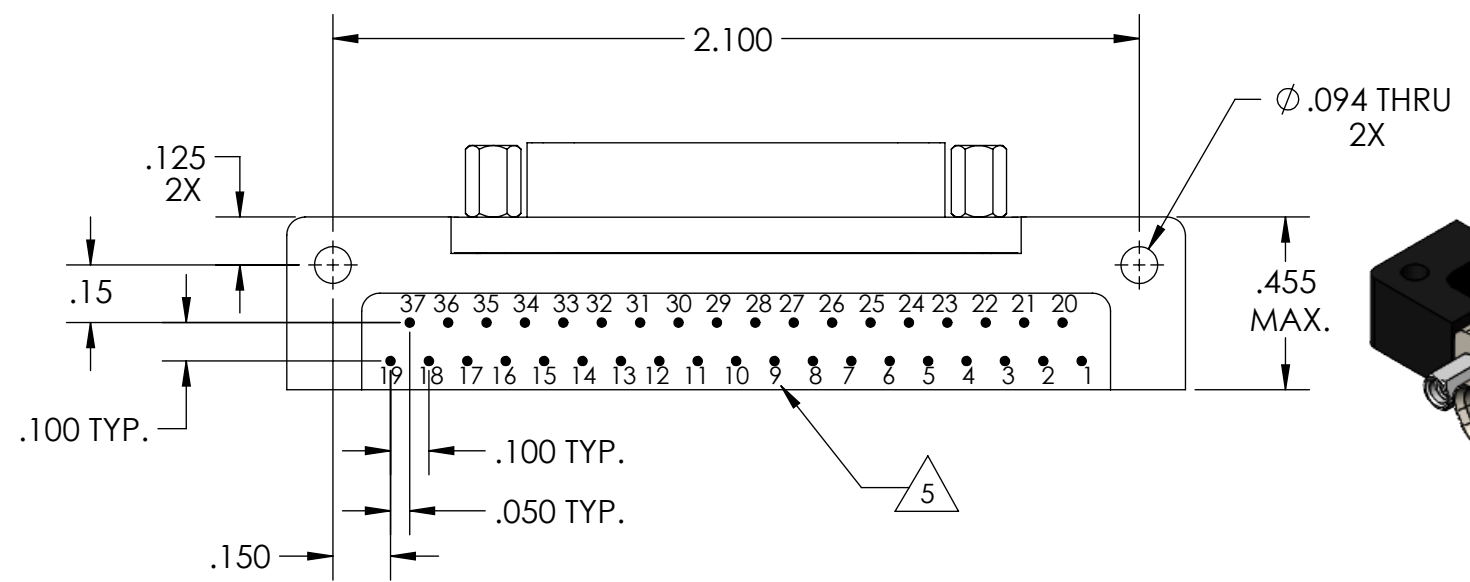
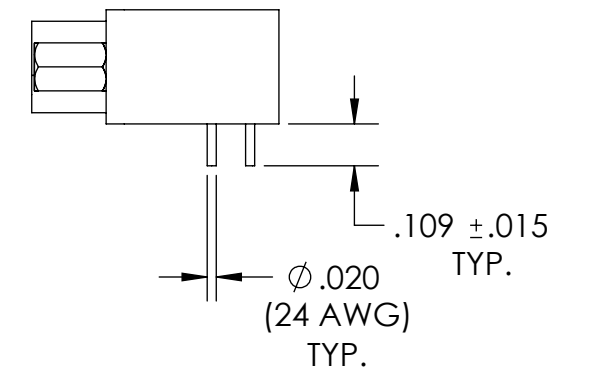
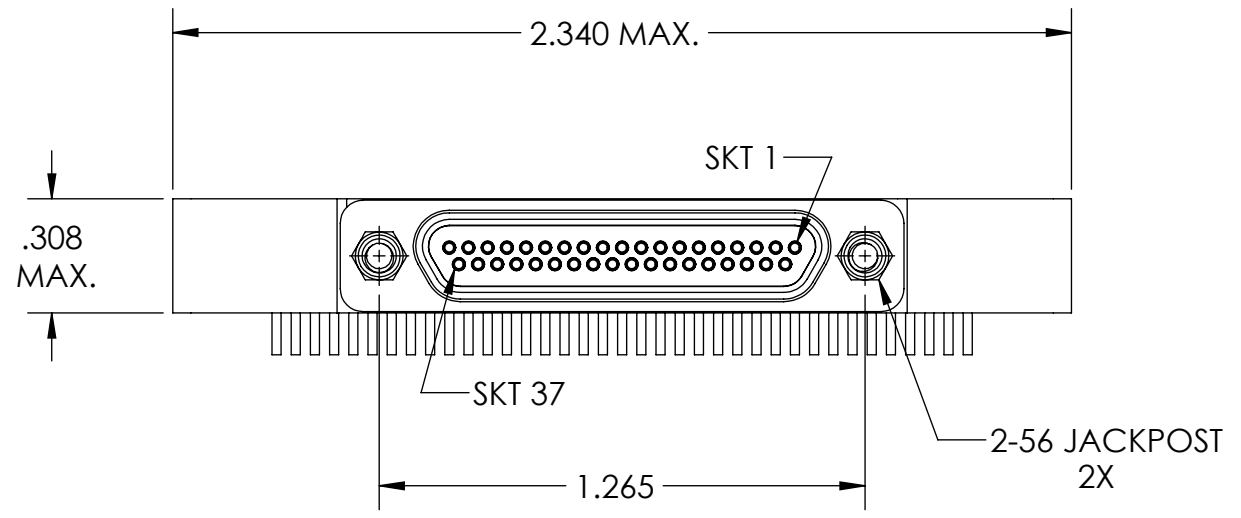

6. CONTACT HEIGHTS ARE TO BE PER QA-STD-101.

5 NUMBERS, (LEAD LOCATIONS), ARE SHOWN FOR REFERENCE ONLY AND DO NOT APPEAR ON ACTUAL PART.

4. PERFORMANCE SPECIFICATIONS:
 CURRENT RATING: 3 AMP MAX.
 DWV: 600 VAC
 TEMPERATURE RATING: -55°C TO 125°C

3 MATERIALS:
 SHELL: 6061-T6 ALUMINUM PER AMS-QQ-A200/8, NICKEL PLATED PER AMS-2404
 INSULATOR/BACKSHELL: PPS PER MIL-M-24519 GST-40F, COLOR: BLACK
 SOCKET CONTACTS: C21000 COPPER ALLOY PER ASTM B36, GOLD PLATED PER ASTM B488
 24 AWG LEADS: TIN PLATED COPPER ALLOY PER A-A-59551, TYPE S
 HARDWARE: PASSIVATED STAINLESS STEEL IAW MIL-DTL-83513/5
 INTERFACIAL SEAL: FLUOROSILICONE PER MIL-R-25988

2. MARKING: "UMI", DATE CODE, UMI PART NUMBER, UMI WORK ORDER NUMBER

1. CONNECTOR ASSEMBLY IS IAW MIL-DTL-83513 WHERE APPLICABLE.

NOTES: UNLESS OTHERWISE SPECIFIED.

QUALITY SYMBOLS CRITICAL MAJOR NO SYMBOLS = MINOR DIMENSIONS	UNLESS OTHERWISE SPECIFIED: ALL DIMENSIONS ARE IN INCHES	SCALE 2:1	DWG SIZE B	THIRD ANGLE PROJECTION	REVISE ON CAD ONLY		
	GENERAL TOLERANCES: 3 PLACES ±.005 2 PLACES ±.01 ANGULAR ±2°	DRAWN BY & DATE DU 9/14/21		TITLE: MICRO-D CIRCUIT CONNECTOR, CM5R37S07-S01			
		CHECKED BY & DATE DW 9/14/21		MATERIAL: 3	ENG PROJECT #: NONE		
		APPROVED BY & DATE DW 9/14/21		PART NO. 836261517	DRAWING NO. SD-836261517		
	ULTI-MATE CAGE CODE 58967	CAD FILE NAME SD-836261517.sliddrw	THIS DRAWING CONTAINS INFORMATION THAT IS PROPRIETARY TO ULTI-MATE INCORPORATED AND SHOULD NOT BE USED WITHOUT WRITTEN PERMISSION.			PART REV. -	