

REVISIONS			
PART REV.	DWG. ISSUE	DATE	ECN NO.
-	-	09/30/22	UMI8153

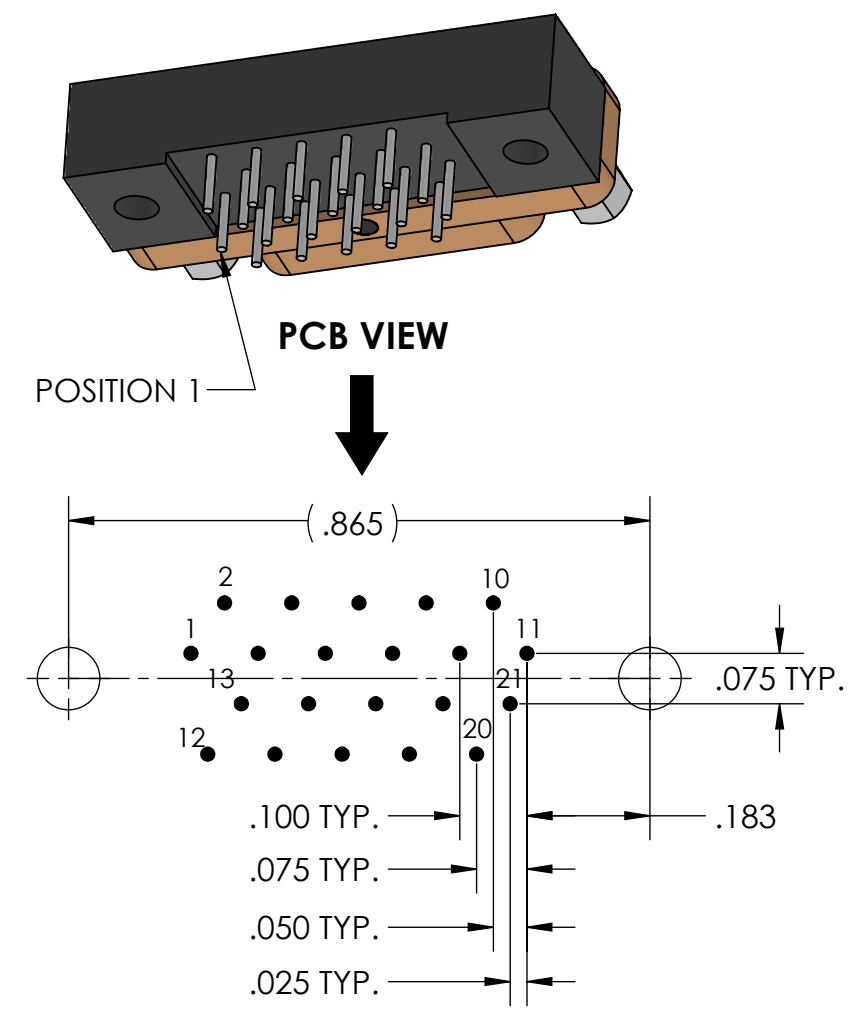

RECOMMENDED PCB LAYOUT

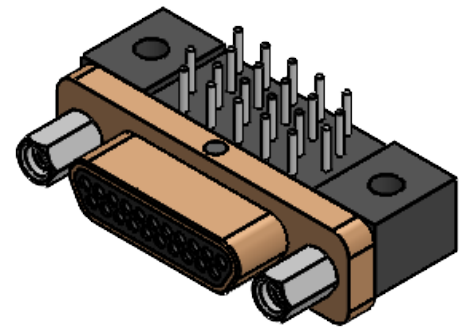
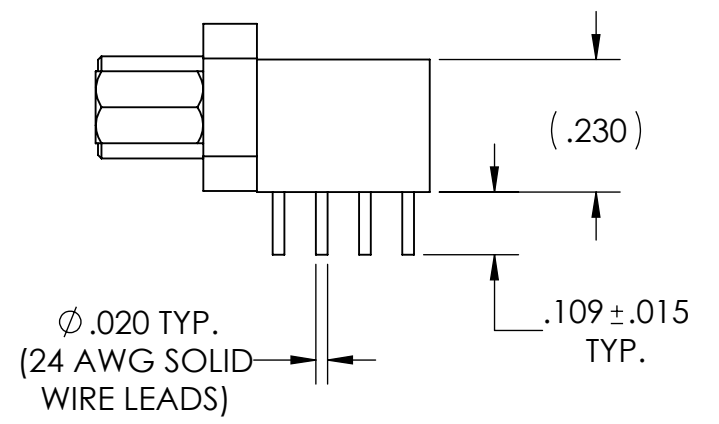
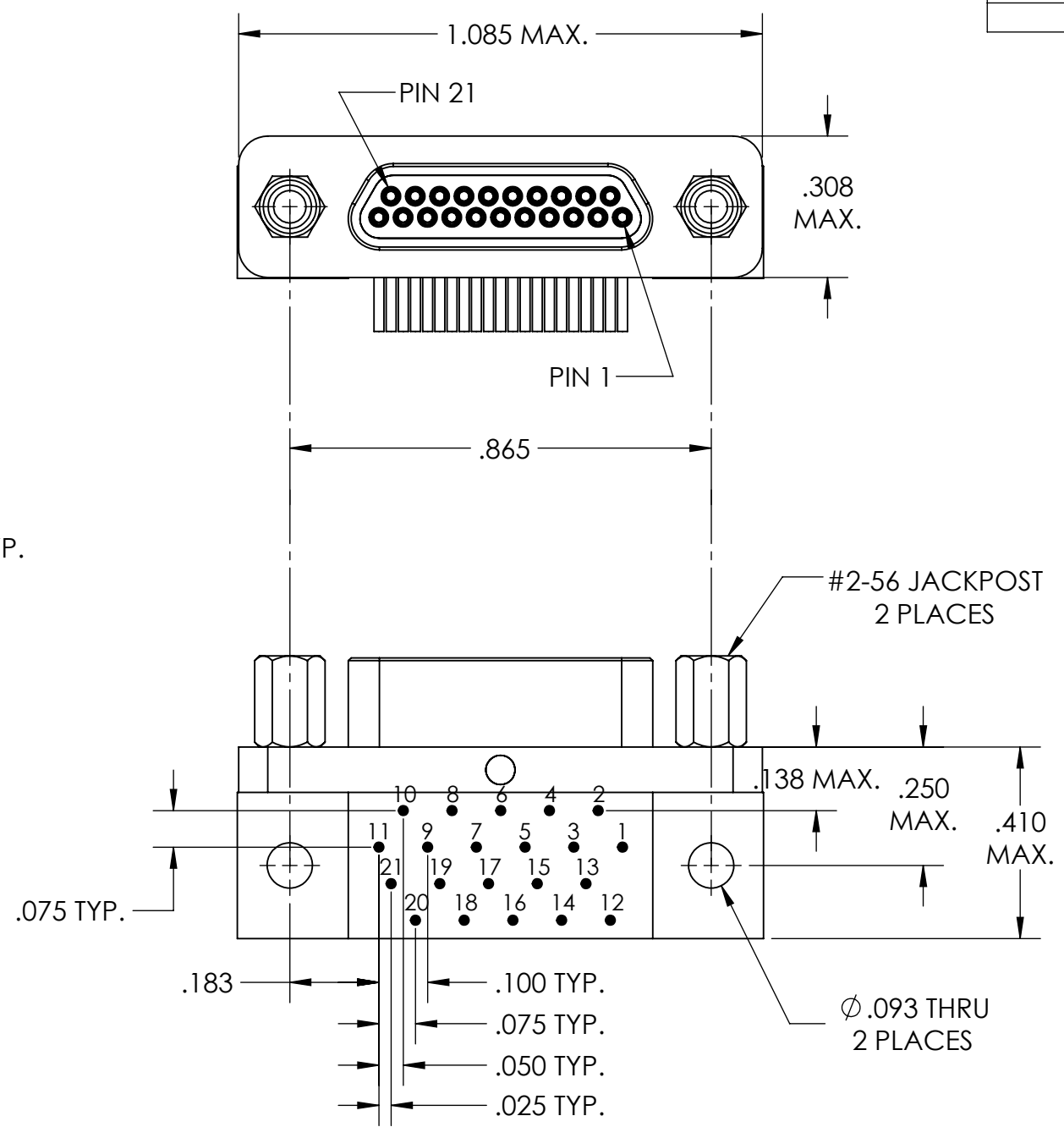

- 6. CONTACT HEIGHTS ARE TO BE PER QA-STD-101.
- 5. LEAD LOCATION NUMBER ARE SHOWN FOR REFERENCE ONLY AND DO NOT APPEAR ON ACTUAL PART.
- 4. PERFORMANCE SPECIFICATIONS:
 CURRENT RATING: 3AMPS MAX.
 INSULATION RESISTANCE: 5000 MΩ MIN.
 DWV: 600 VAC
 TEMPERATURE RATING: -55°C TO 125°C
- 3. MATERIALS:
 SHELL: 6061-T6 ALUMINUM PER AMS-QQ-A200/8, CADMIUM PLATED PER AMS-QQ-P-416
 INSULATOR AND BACKSHELL: PPS PER MIL-M-24519 GST-40F, COLOR: BLACK
 PIN CONTACTS: C17200 BERYLLIUM COPPER PER ASTM B194, GOLD PLATED PER ASTM B488
 24 AWG LEADS: TIN PLATED COPPER ALLOY PER A-A-59551, TYPE S
 HARDWARE: PASSIVATED STAINLESS STEEL IAW MIL-DTL-83513/5
- 2. MARKING: "UMI", DATE CODE, UMI P/N AND WORK ORDER NUMBER
- 1. CONNECTOR ASSEMBLY IS IAW MIL-DTL-83513 UNLESS OTHERWISE SPECIFIED.

NOTES: UNLESS OTHERWISE SPECIFIED

QUALITY SYMBOLS CRITICAL MAJOR NO SYMBOL = MINOR DIMENSION	UNLESS SPECIFIED: ALL DIMENSIONS IN INCHES GENERAL TOLERANCES: 3 PLACE ±.005 2 PLACE ±.01 ANGULAR ±2° ALL EXTERNAL SPECIFICATIONS REFERENCED ON THIS DRAWING SHALL BE THE LATEST REVISION IN EFFECT UMI-Mate CAGE CODE 58967	SCALE NONE	DWG SIZE B	THIRD ANGLE PROJECTION	REVISE ON CAD ONLY	
	DRAWN BY N.DO	TITLE MICRO-D CIRCUIT CONNECTOR SIZE 21, PLUG CM8R21P07		MATERIAL 3	ENG PROJECT # NONE	
	DATE DRAWN 09/30/2022	CAD FILENAME SD-836130817.slddrw	PART NO. 836130817	DRAWING NO. SD-836130817	SHEET NO. 1 OF 1	
	THIS DRAWING CONTAINS INFORMATION THAT IS PROPRIETARY TO ULTI-MATE INCORPORATED AND SHOULD NOT BE USED WITHOUT WRITTEN PERMISSION.				PART REV. -	