

REVISIONS				
PART REV.	DWG. ISSUE	DATE	ECN NO.	ENGINEER
-	-	1/26/23	UMI8250	JD

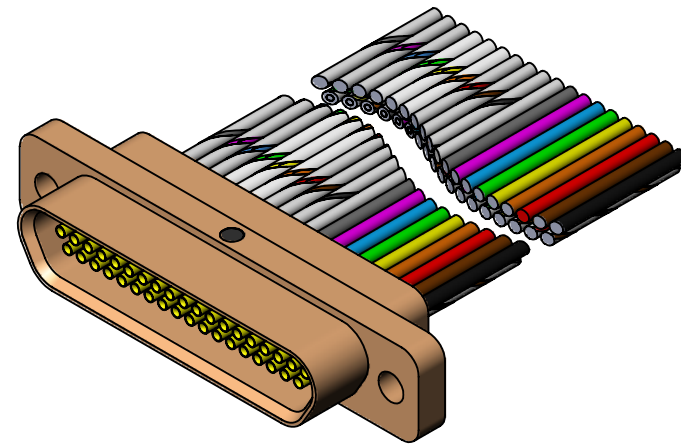
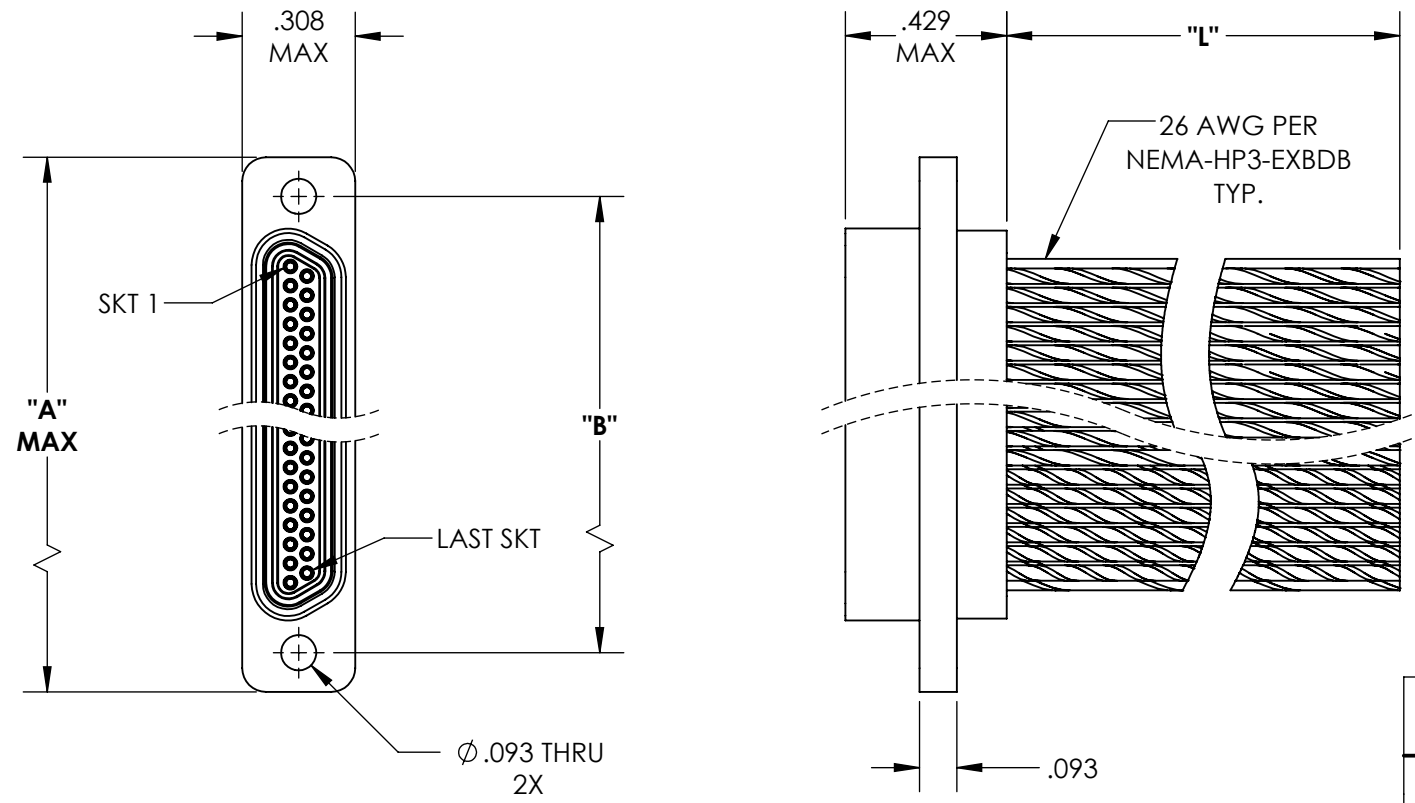

SIZE 37 SHOWN

PART #	SIZE	A	B	L
834210020	09	0.785	0.565	12.0 +1.0 -0.0
834219128	09	0.785	0.565	20.0 +2.0 -0.0
834210030	09	0.785	0.565	72.0 +4.0 -0.0
834229048	15	0.935	0.715	20.0 +2.0 -0.0
834220150	15	0.935	0.715	48.0 +2.0 -0.0
834230030	21	1.085	0.865	72.0 +4.0 -0.0
834240020	25	1.185	0.965	12.0 +1.0 -0.0
834240030	25	1.185	0.965	72.0 +4.0 -0.0
834260030	37	1.485	1.265	72.0 +4.0 -0.0

1	BLK	20	W/BLK/BRN
2	BRN	21	W/BLK/RED
3	RED	22	W/BLK/ORG
4	ORG	23	W/BLK/YEL
5	YEL	24	W/BLK/GRN
6	GRN	25	W/BLK/BLU
7	BLU	26	W/BLK/VIO
8	VIO	27	W/BLK/GRY
9	GRY	28	W/BRN/RED
10	WHT	29	W/BRN/ORG
11	W/BLK	30	W/BRN/YEL
12	W/BRN	31	W/BRN/GRN
13	W/RED	32	W/BRN/BLU
14	W/ORG	33	W/BRN/VIO
15	W/YEL	34	W/BRN/GRY
16	W/GRN	35	W/RED/ORG
17	W/BLU	36	W/RED/YEL
18	W/VIO	37	W/RED/GRN
19	W/GRY		

- 5. CONTACT HEIGHTS ARE TO BE PER QA-STD-101
- 4. PERFORMANCE SPECIFICATIONS:
CURRENT RATING: 3A MAX.
INSULATION RESISTANCE: 5000 MΩ MIN.
DWV: 600 VAC; AT 70,000 FT; 150 VAC
TEMPERATURE RATING: 125°C

- 3. MATERIALS:
SHELL: 6061-T6 ALUMINUM PER AMS-QQ-A200/8, CADMIUM PLATED PER AMS-QQ-P-416
INSULATOR: PPS PER MIL-M-24519 GST-40F, COLOR: BLK
SOCKET CONTACTS: C21000 BRASS ALLOY PER ASTM B36, GOLD PLATED PER ASTM B488
WIRE: 26 AWG PER NEMA-HP3-EXBDB, COLOR CODE: PER MIL-STD-681
INTERFACIAL SEAL: FLUOROSILICONE PER MIL-R-25988

1. CONNECTOR ASSEMBLY IS IAW MIL-DTL-83513 UNLESS OTHERWISE SPECIFIED

NOTES: UNLESS OTHERWISE SPECIFIED

QUALITY SYMBOLS CRITICAL MAJOR NO SYMBOL = MINOR DIMENSION	UNLESS SPECIFIED: ALL DIMENSIONS IN INCHES/MM GENERAL TOLERANCES: 3 PLACE ±.005 2 PLACE ±.01 ANGULAR ±2° ALL EXTERNAL SPECIFICATIONS REFERENCED ON THIS DRAWING SHALL BE THE LATEST REVISION IN EFFECT Ulti-Mate CAGE CODE 58967	SCALE 2:1	DWG SIZE B	THIRD ANGLE PROJECTION	REVISE ON CAD ONLY	
		DRAWN BY JD	TITLE MICRO-D CONNECTOR ASSEMBLY, NON-STANDARD WIRE LENGTH, MRXXS0-26E5-XX.X			
		DATE DRAWN 1/26/23	MATERIAL 3	ENG PROJECT # TR1771		
		CAD FILENAME SD-834240020.slddrw	PART NO. SEE TABLE	DRAWING NO. SD-834240020	SHEET NO. 1 OF 1	
THIS DRAWING CONTAINS INFORMATION THAT IS PROPRIETARY TO ULTI-MATE INCORPORATED AND SHOULD NOT BE USED WITHOUT WRITTEN PERMISSION.						
				PART REV. -		