

PART DWG REV ISSUE	DATE	ECN NO.	APPD BY	REL BY
-	12/28/12	UM4838		

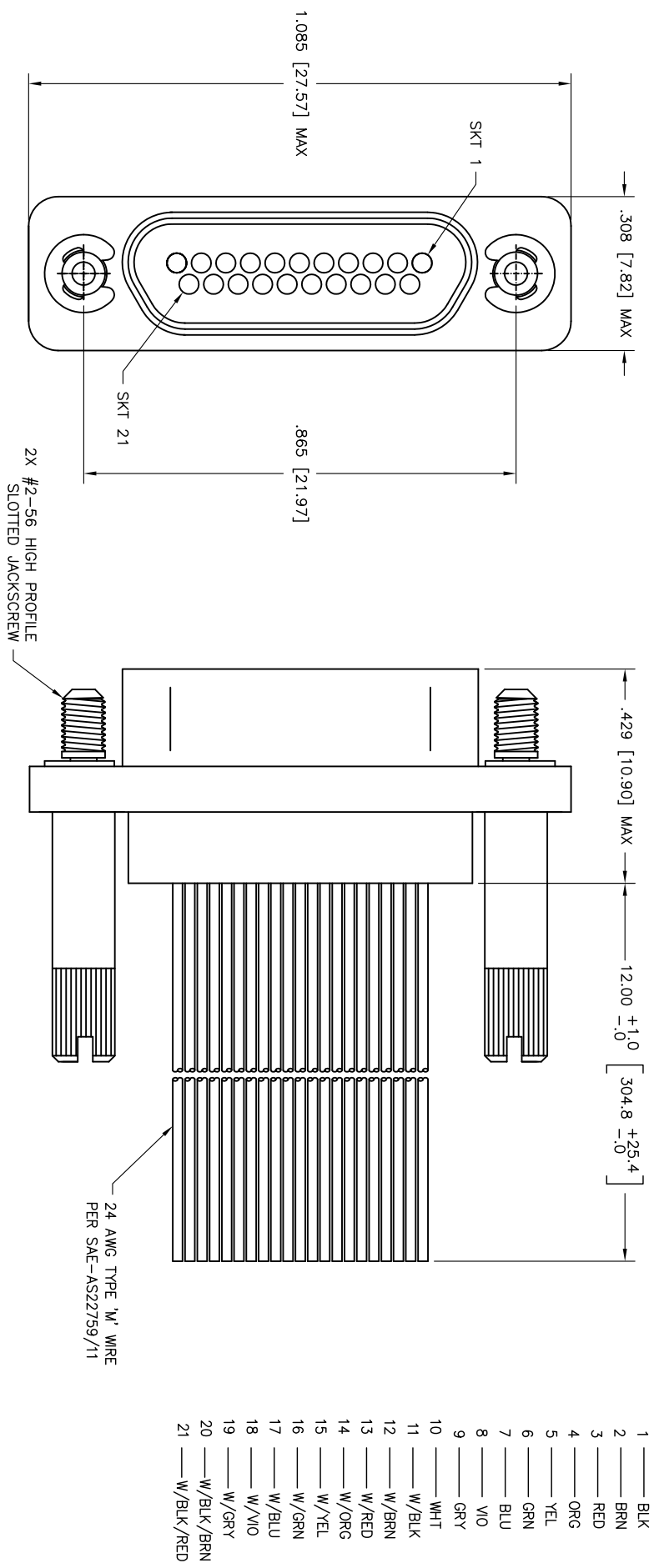

1. MARKINGS: UMI, DATE CODE, UMI P/N AS SPACE PERMITS  
 NOTES: UNLESS OTHERWISE SPECIFIED

QUALITY SYMBOLS	UNLESS SPECIFIED, ALL DIMENSIONS IN INCHES	SCALE	DWG SIZE	THIRD ANGLE PROJECTION	REVISE ON CAD ONLY
MAJOR = MINOR = CRITICAL = SPC = S =	GENERAL TOLERANCES: 3 PLACE ±.005 2 PLACE ±.010 ANGULAR ±.2°	5:1	B		
		DRAWN BY & DATE		TITLE	
		PR 12-27-12		MICRO-D, RECEPTACLE, SOCKET CONTACTS	
		CHECKED BY & DATE		SIZE 21, 24 AWG LEADS, MR21S06-24W5-12.0	
		APPROVED BY & DATE		MATERIAL	
		CAD FILENAME			
		SD-834230466.DWG			
		PART NO.		DRAWING NO.	
		834230466		SD-834230466	
				SHEET NO.	
				1 OF 1	
				REV	

THIS DRAWING CONTAINS INFORMATION THAT IS PROPRIETARY TO ULTI-MATE INCORPORATED AND SHOULD NOT BE USED WITHOUT WRITTEN PERMISSION.