

| PART REV | DWG ISSUE | DATE | ECN NO. | APPVD BY | REL BY |
|----------|-----------|---------|---------|----------|--------|
| - | - | 10/8/12 | UMI4746 | JB | DW |

F
E
D
C
B
A

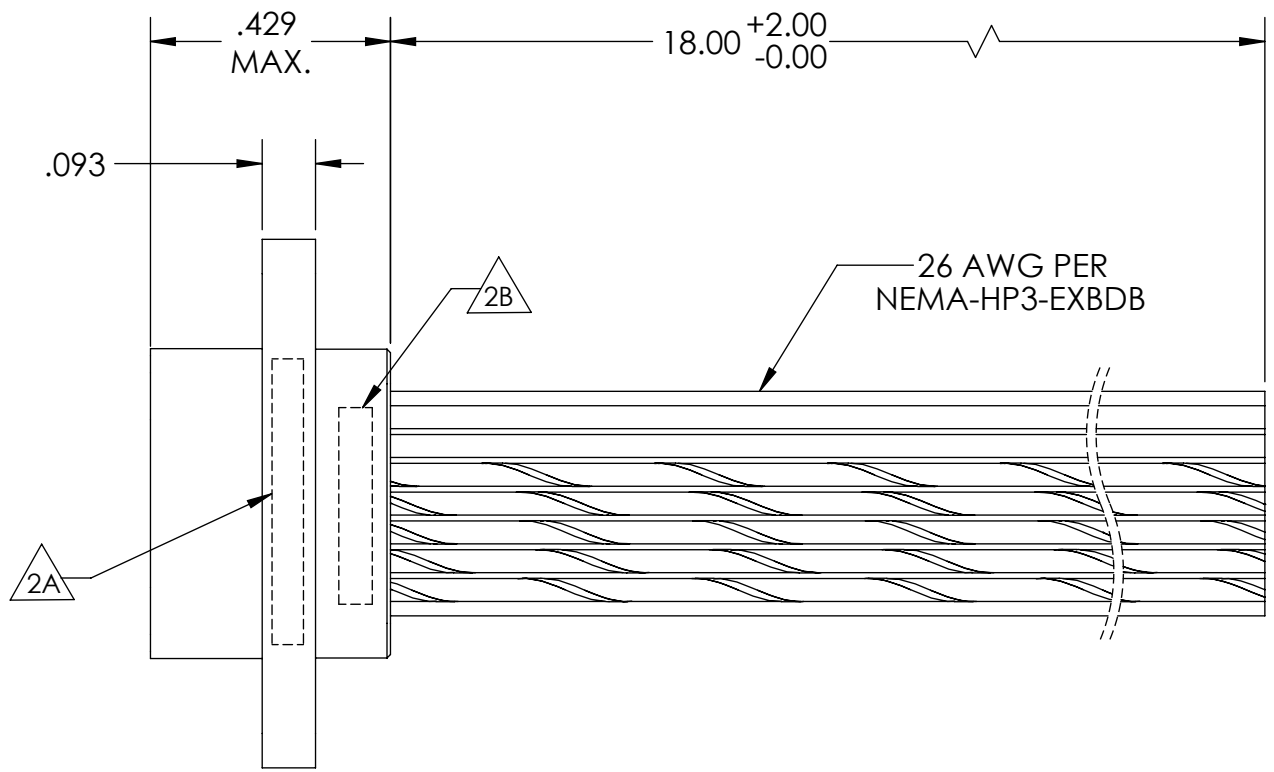

| | |
|----|-------|
| 1 | BLK |
| 2 | BRN |
| 3 | RED |
| 4 | ORG |
| 5 | YEL |
| 6 | GRN |
| 7 | BLU |
| 8 | VIO |
| 9 | GRY |
| 10 | WHT |
| 11 | W/BLK |
| 12 | W/BRN |
| 13 | W/RED |
| 14 | W/ORG |
| 15 | W/YEL |

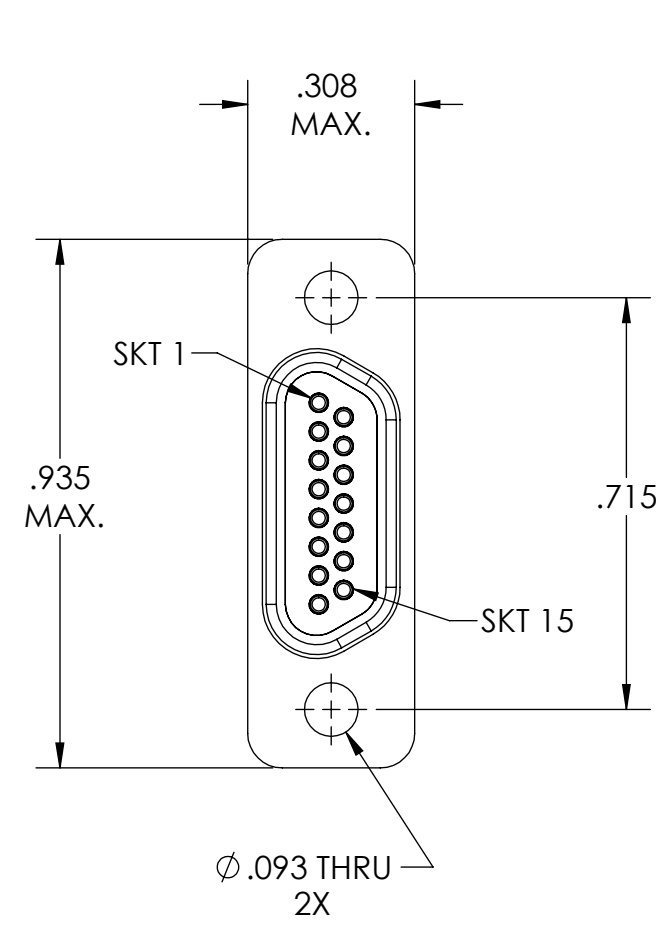
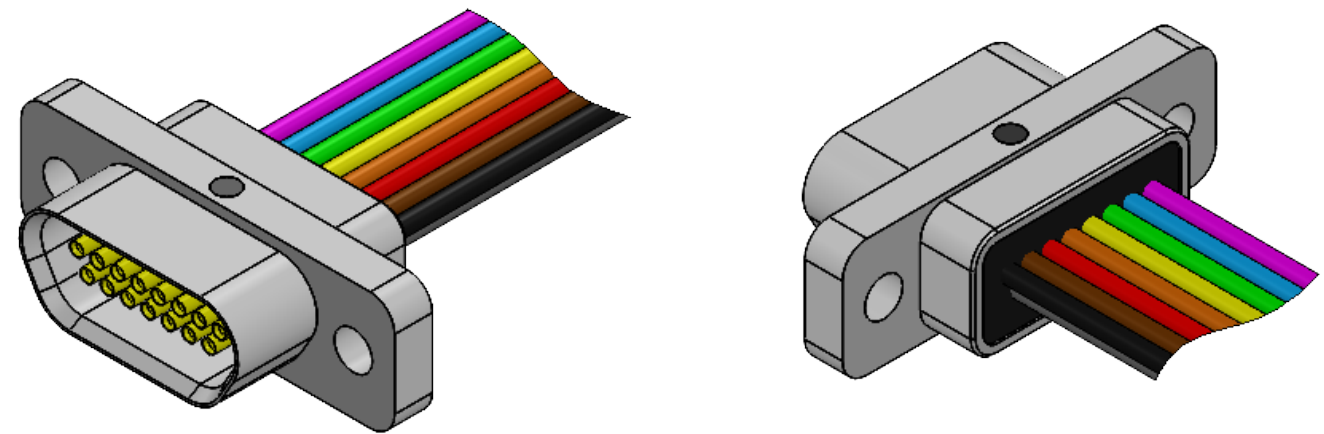

- 5. CONTACT HEIGHTS ARE TO BE PER QA-STD-101.
- 4. PERFORMANCE SPECIFICATIONS:
CURRENT RATING: 3 AMPS MAX.
INSULATION RESISTANCE: 5000 MEGOHMS MIN.
DWV: 600 VAC
TEMPERATURE RATING: 125° C

3 MATERIALS:
SHELL: 6061-T6 ALUMINUM PER AMS-Q-Q-A200/8, NICKEL PLATED PER AMS-2404
INSULATOR: PPS PER MIL-M-24519 GST-40F, COLOR: BLACK
SOCKET CONTACTS: C21000 COPPER ALLOY PER ASTM B36, GOLD PLATED PER ASTM B488
WIRE: 26 AWG PER NEMA-HP3-EXBDB, COLOR CODE PER MIL-STD-681
INTERFACIAL SEAL: FLUOROSILICONE PER MIL-R-25988

- 2. MARKING: 2A "UMI", UMI PART NUMBER
2B DATE CODE, UMI WORK ORDER NUMBER

1. CONNECTOR ASSEMBLY IS IAW MIL-DTL-83513 UNLESS OTHERWISE SPECIFIED.
NOTES: UNLESS OTHERWISE SPECIFIED.

| | | | | | | |
|---|---|----------------------------------|--------------------------------------|---|------------------------------|----------------|
| QUALITY SYMBOLS CRITICAL C MAJOR NO SYMBOLS = MINOR DIMENSIONS | UNLESS OTHERWISE SPECIFIED: ALL DIMENSIONS ARE IN INCHES | SCALE 3:1 | DWG SIZE B | THIRD ANGLE PROJECTION | REVISE ON CAD ONLY | |
| | GENERAL TOLERANCES: 3 PLACES ±.005 2 PLACES ±.01 ANGULAR ±2° | DRAWN BY & DATE JB 10/8/12 | | TITLE: MICRO-D CONNECTOR ASSEMBLY, MR15S0-26E5-18.0-S01 | | |
| | | CHECKED BY & DATE DW 10/8/12 | | MATERIAL: 3 | ENG PROJECT #: NONE | |
| | | APPROVED BY & DATE DW 10/8/12 | | | DRAWING NO.: SD-834221070 | |
| | ULTI-MATE CAGE CODE 58967 | | CAD FILE NAME SD-834221070.SLDDRW | PART NO. 834221070 | SHEET NO. 1 of 1 | PART REV. - |

THIS DRAWING CONTAINS INFORMATION THAT IS PROPRIETARY TO ULTI-MATE INCORPORATED AND SHOULD NOT BE USED WITHOUT WRITTEN PERMISSION.

