

PART REV	DWG ISSUE	DATE	ECN NO.	APPVD BY	REL BY
-	-	12/6/21	UMI7915	DU	DW

F
E
D
C
B
A

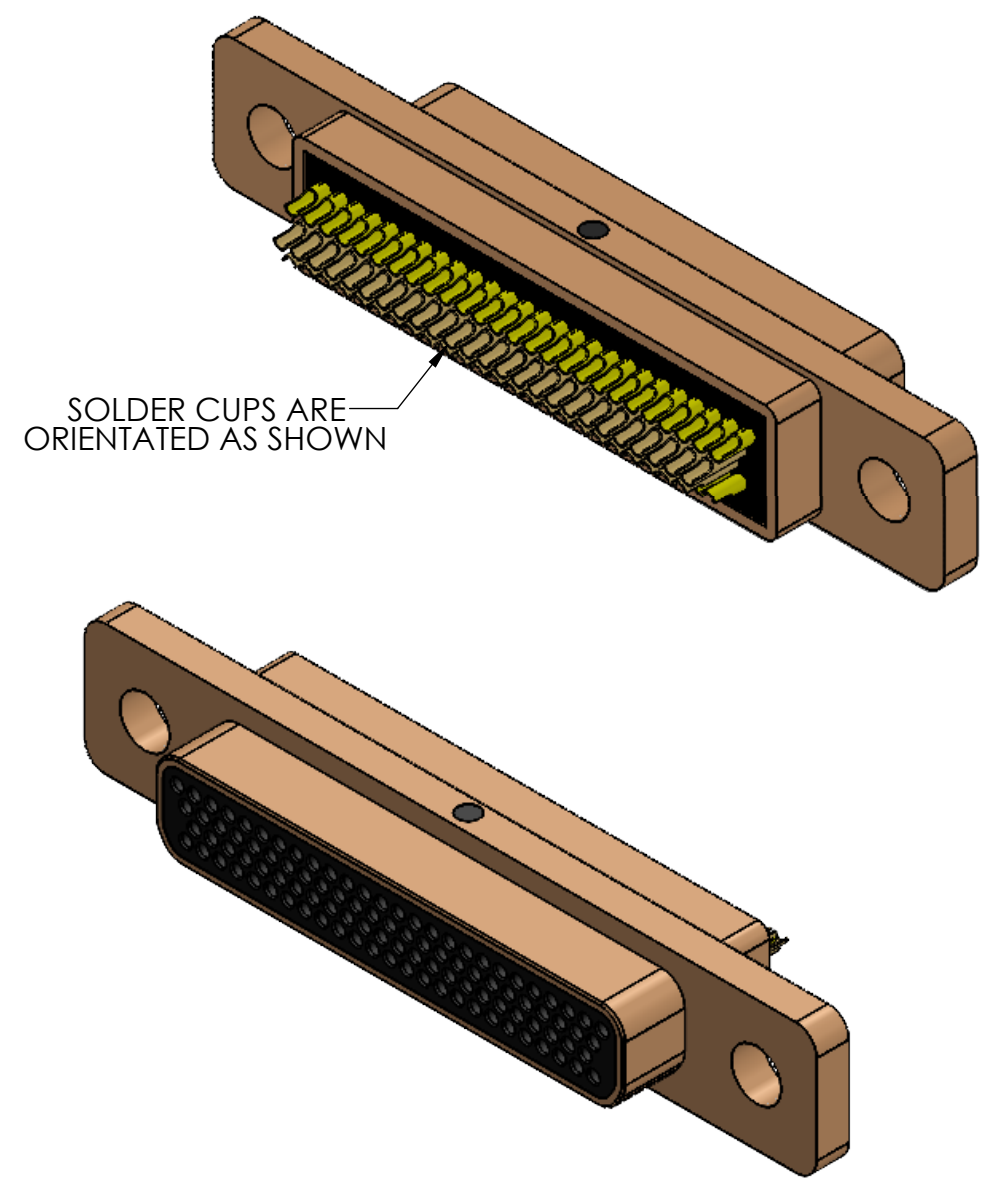
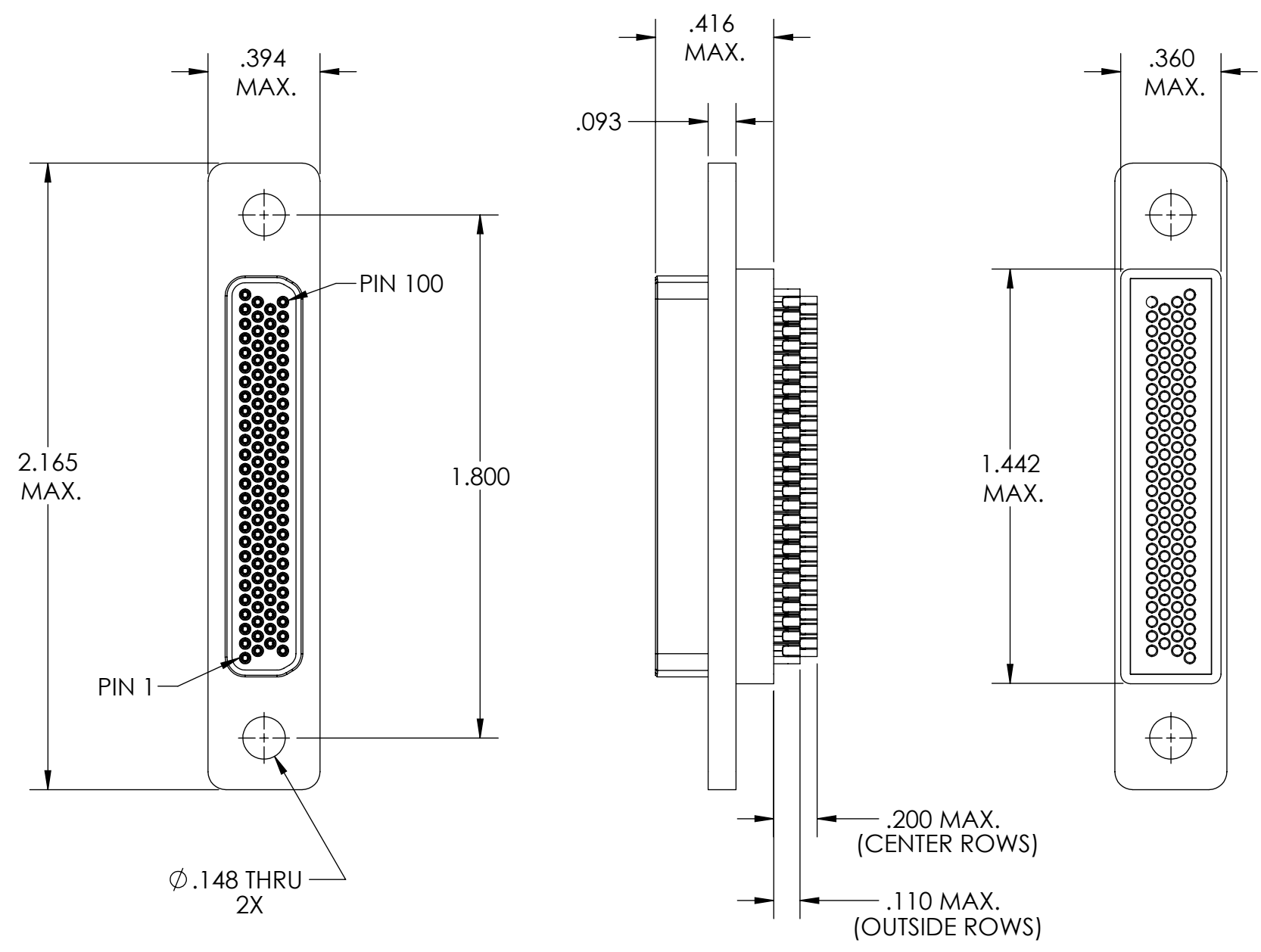

- 5. CONTACT HEIGHTS ARE TO BE PER QA-STD-101.
- 4. PERFORMANCE SPECIFICATIONS:
CURRENT RATING: 3 AMPS MAX.
DWV: 600 VAC
TEMPERATURE RATING: -55 C TO 125° C

3 MATERIALS:
SHELL: 6061-T6 ALUMINUM PER AMS-Q-Q-A200/8, CADMIUM PLATED PER AMS-QQ-P-416
INSULATOR: PPS PER MIL-M-24519 GST-40F, COLOR: BLACK
PIN SOLDER CUP CONTACTS: C17200 BERYLLIUM COPPER PER ASTM B194, GOLD PLATED PER ASTM B488

- 2. MARKING: "UMI", DATE CODE, UMI PART NUMBER, UMI WORK ORDER NUMBER
- 1. CONNECTOR ASSEMBLY IS IAW MIL-DTL-83513 WHERE APPLICABLE.

NOTES: UNLESS OTHERWISE SPECIFIED.

QUALITY SYMBOLS CRITICAL MAJOR NO SYMBOLS = MINOR DIMENSIONS	UNLESS OTHERWISE SPECIFIED; ALL DIMENSIONS ARE IN INCHES	SCALE 2:1	DWG SIZE B	THIRD ANGLE PROJECTION 	REVISE ON CAD ONLY		
	GENERAL TOLERANCES: 3 PLACES ±.005 2 PLACES ±.01 ANGULAR ±2°	DRAWN BY & DATE DU 12/6/21	TITLE: MICRO-D CONNECTOR ASSEMBLY, MR100N0, CADMIUM PLATED, W/SOLDER CUPS		MATERIAL: 3	ENG PROJECT #: NONE	 Ulti-Mate Connector Inc.
	ULTI-MATE CAGE CODE 58967	CHECKED BY & DATE DW 12/6/21	PART NO. 834180000		DRAWING NO. SD-834180000	SHEET NO. 1 of 1	
		APPROVED BY & DATE DW 12/6/21	CAD FILE NAME SD-834180000.SLDDRW		THIS DRAWING CONTAINS INFORMATION THAT IS PROPRIETARY TO ULTI-MATE INCORPORATED AND SHOULD NOT BE USED WITHOUT WRITTEN PERMISSION.		