

3			2		
PART REV	DWG ISSUE	DATE	ECN NO.	APPVD BY	REL BY
-	-	4/1/21	UMI7718	DU	DW

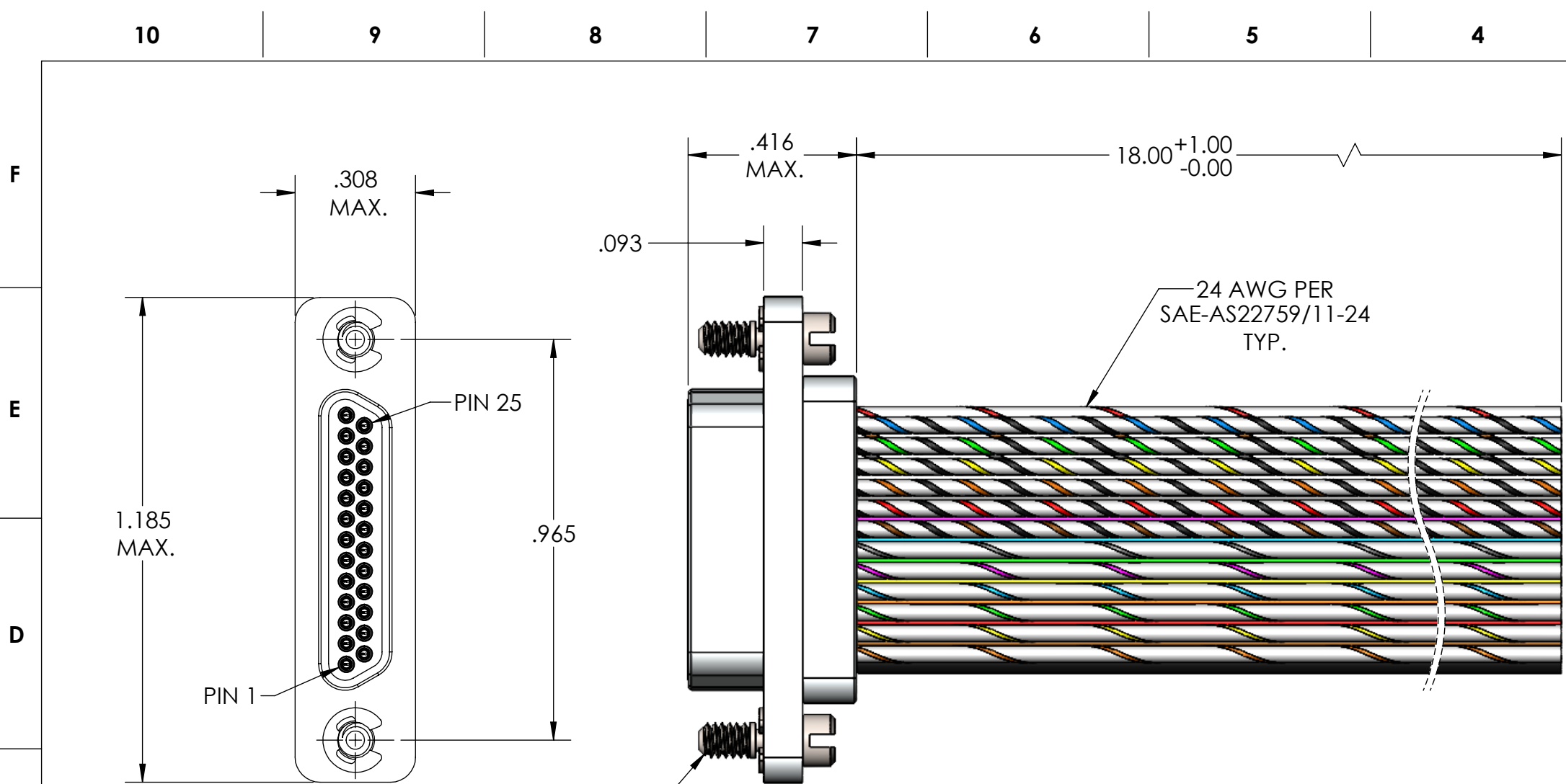

1	BLK
2	BRN
3	RED
4	ORG
5	YEL
6	GRN
7	BLU
8	VIO
9	GRY
10	WHT
11	W/BLK
12	W/BRN
13	W/RED
14	W/ORG
15	W/YEL
16	W/GRN
17	W/BLU
18	W/VIO
19	W/GRY
20	W/BLK/BRN
21	W/BLK/RED
22	W/BLK/ORG
23	W/BLK/YEL
24	W/BLK/GRN
25	W/BLK/BLU

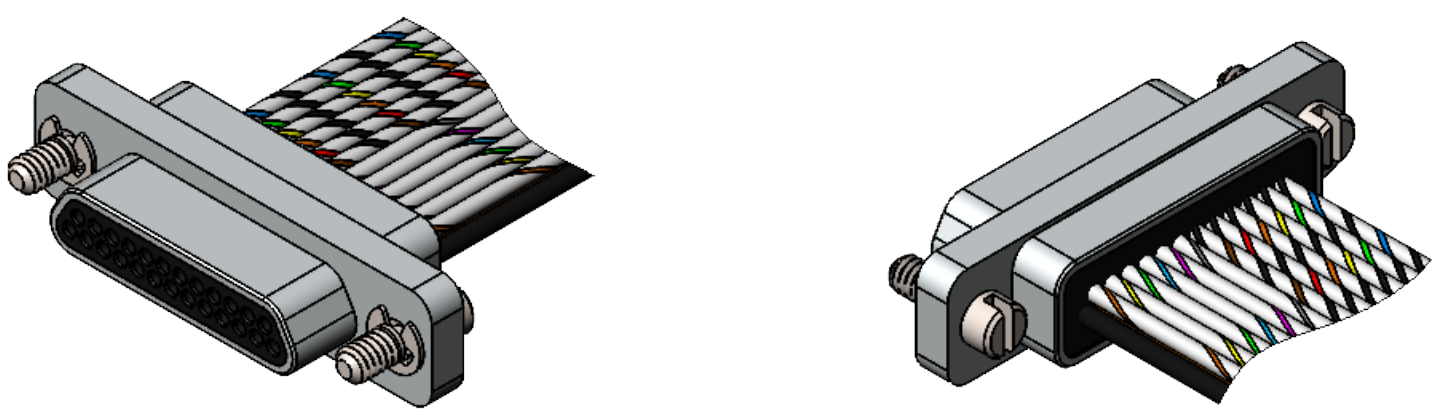

- 5. CONTACT HEIGHTS ARE TO BE PER QA-STD-101.
- 4. PERFORMANCE SPECIFICATIONS:
CURRENT RATING: 3 AMPS MAX.
DWV: 600 VAC
TEMPERATURE RATING: -55°C TO 125°C

3 MATERIALS:
SHELL: 6061-T6 ALUMINUM PER AMS-Q-Q-A200/8, NICKEL PLATED PER AMS-2404
INSULATOR: PPS PER MIL-M-24519 GST-40F, COLOR: BLACK
PIN CONTACTS: C17200 BERYLLIUM COPPER PER ASTM B194, GOLD PLATED PER ASTM B488
HARDWARE: PASSIVATED STAINLESS STEEL IAW MIL-DTL-83513/5
WIRE: 24 AWG PER SAE-AS22759/11-24, COLOR CODE PER MIL-STD-681

- 2. MARKING: "UMI", DATE CODE, UMI PART NUMBER, UMI WORK ORDER NUMBER
- 1. CONNECTOR ASSEMBLY IS IAW MIL-DTL-83513 WHERE APPLICABLE.

NOTES: UNLESS OTHERWISE SPECIFIED.

QUALITY SYMBOLS CRITICAL MAJOR NO SYMBOLS = MINOR DIMENSIONS	UNLESS OTHERWISE SPECIFIED: ALL DIMENSIONS ARE IN INCHES	SCALE 3:1	DWG SIZE B	THIRD ANGLE PROJECTION	REVISE ON CAD ONLY	
	GENERAL TOLERANCES: 3 PLACES ±.005 2 PLACES ±.01 ANGULAR ±2°	DRAWN BY & DATE DU 4/1/21		TITLE: MICRO-D CONNECTOR ASSEMBLY, MR25P05-24M5-18.0-S01		
	ULTI-MATE CAGE CODE 58967	CHECKED BY & DATE DW 4/1/21		MATERIAL: 3		
		APPROVED BY & DATE DW 4/1/21		ENG PROJECT #: NONE		
		CAD FILE NAME SD-834141745.SLDDRW	PART NO. 834141745	DRAWING NO. SD-834141745	SHEET NO. 1 of 1	
THIS DRAWING CONTAINS INFORMATION THAT IS PROPRIETARY TO ULTI-MATE INCORPORATED AND SHOULD NOT BE USED WITHOUT WRITTEN PERMISSION.						