

3			2		
PART REV	DWG ISSUE	DATE	ECN NO.	APPVD BY	REL BY
-	-	04/12/18	UMI6731	T.POMBART	PER

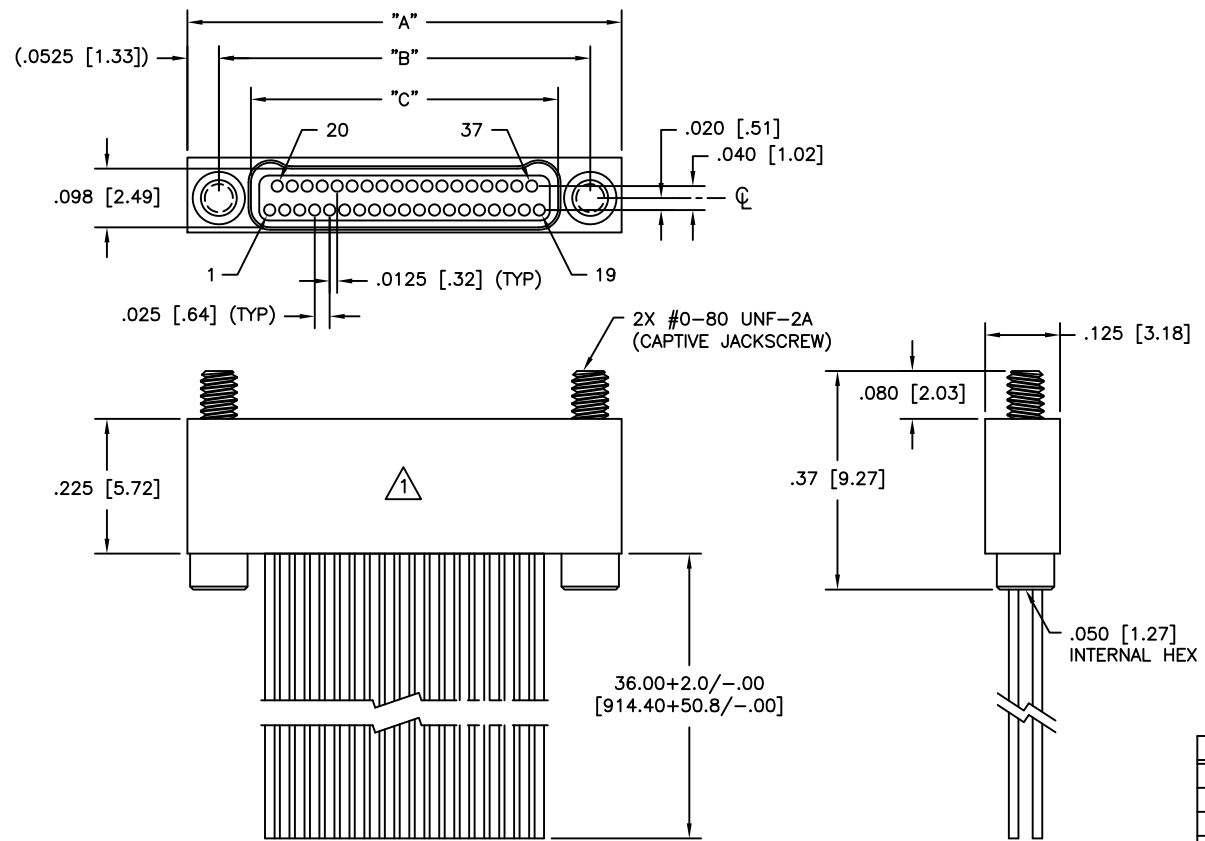

WIRING COLOR CODE

1, 11, 21, 31, 41, 51, 61	—	BLACK
2, 12, 22, 32, 42, 52, 62	—	BROWN
3, 13, 23, 33, 43, 53, 63	—	RED
4, 14, 24, 34, 44, 54, 64	—	ORANGE
5, 15, 25, 35, 45, 55, 65	—	YELLOW
6, 16, 26, 36, 46, 56	—	GREEN
7, 17, 27, 37, 47, 57	—	BLUE
8, 18, 28, 38, 48, 58	—	VIOLET
9, 19, 29, 39, 49, 59	—	GRAY
10, 20, 30, 40, 50, 60	—	WHITE

WIRE DIAGRAM REPRESENTS LARGEST SIZE IN PART NO. TABLE

PART NO.	SIZE	"A"	"B"	"C"
833411632	9	.375 [9.52]	.270 [6.86]	.163 [4.14]
833421632	15	.450 [11.43]	.345 [8.76]	.238 [6.04]
833431632	21	.525 [13.33]	.420 [10.67]	.313 [7.95]
833441632	25	.575 [14.60]	.470 [11.94]	.363 [9.22]
833451632	31	.650 [16.51]	.545 [13.84]	.438 [11.12]
833461632	37	.725 [18.41]	.620 [15.75]	.513 [13.03]
833471632	51	.900 [22.86]	.795 [20.19]	.688 [17.47]
833481632	65	1.075 [27.30]	.970 [24.64]	.863 [21.92]

3. PERFORMANCE: MANUFACTURED TO MEET OR EXCEED THE FOLLOWING M32139 PERFORMANCE SPECIFICATIONS
 CONTACT RATING: 1 AMPERE MAXIMUM
 DWV: 250 VAC
 INSULATION RESISTANCE: 5000 MEGOHMS MINIMUM @ 100 VDC
 CONTACT RESISTANCE: 0.071 VOLT MAXIMUM DROP @ 1.0 AMPS (.071 OHMS)
 W/6.00" OF WIRE LISTED BELOW, PER MIL-DTL-32139

2. MATERIALS: SHELL: ALUMINUM 6061-T6, ELECTROLESS NICKEL PLATED PER AMS2404
 INSULATOR: LCP (LIQUID CRYSTAL POLYMER) GLCP-30F
 CONTACT: BRASS ALLOY 260, GOLD PLATED PER ASTM B488
 LEADS: 30 AWG, NEMA HP3, TYPE ET, COLOR CODED PER MIL-DTL-681, SYSTEM 1, EXCEPT USING 10 SOLID REPEATING COLORS
 HARDWARE: 303 STAINLESS PER ASTM 582

1. MARKINGS: UMI, UMI P/N, DATE CODE & W/O NO. AS SPACE PERMITS OTHERWISE ON BAG OR TAG

NOTES: UNLESS OTHERWISE SPECIFIED

QUALITY SYMBOLS MAJOR = CRITICAL = C = SPC = S =	UNLESS SPECIFIED: ALL DIMENSIONS IN INCHES GENERAL TOLERANCES: 3 PLACE ±.005 2 PLACE ±.010 ANGULAR ±2°	SCALE 5:1 DWG SIZE B DRAWN BY & DATE UMI 03-09-10 CHECKED BY & DATE SEE ECN APPROVED BY & DATE SEE ECN CAD FILENAME SD-833461632.DWG	THIRD ANGLE PROJECTION REVISE ON CAD ONLY TITLE: NANO-D DUAL ROW CONNECTOR FEMALE, SIZE XX, NMLXX-2S02-30F6-36.0 S01 MATERIAL:
	Ulti-Mate CAGE CODE 58967	PART NO. SEE "TAB BLOCK" DRAWING NO. SD-833461632 SHEET NO. 1 OF 1	Ulti-Mate Connector Inc.
	THIS DRAWING CONTAINS INFORMATION THAT IS PROPRIETARY TO ULTI-MATE INCORPORATED AND SHOULD NOT BE USED WITHOUT WRITTEN PERMISSION.		
	PART REV -		