

PART DWG REV ISSUE	DATE	ECN NO.	APPRD BY	REL BY
-	01/09/15	UMISS03	TPOWERART	PER

WIRING COLOR CODE

- 1, 11, 21, 31 — BLACK
- 2, 12, 22, 32 — BROWN
- 3, 13, 23, 33 — RED
- 4, 14, 24, 34 — ORANGE
- 5, 15, 25, 35 — YELLOW
- 6, 16, 26, 36 — GREEN
- 7, 17, 27, 37 — BLUE
- 8, 18, 28 — VIOLET
- 9, 19, 29 — GRAY
- 10, 20, 30 — WHITE

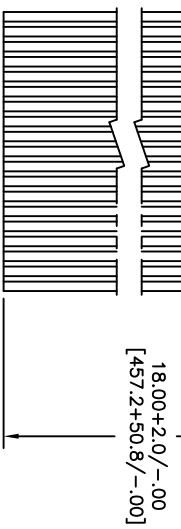
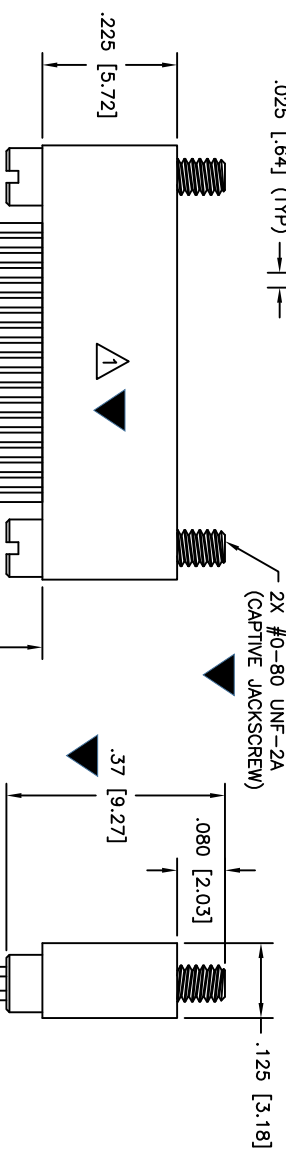
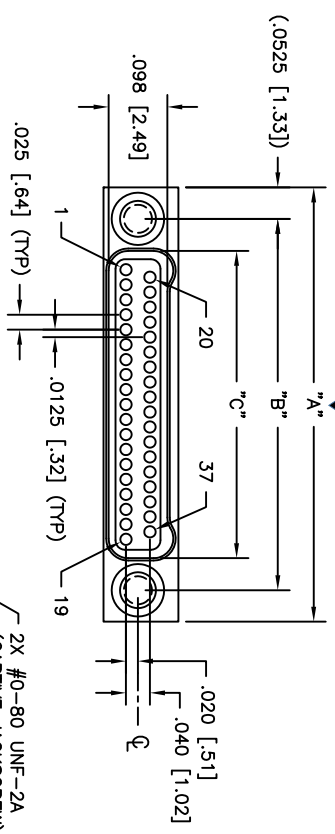

PART NO.	SIZE	"A"	"B"	"C"
833411625	9	.375 [9.52]	.270 [6.86]	.163 [4.14]
833421625	15	.450 [11.43]	.345 [8.76]	.238 [6.04]
833431625	21	.525 [13.33]	.420 [10.67]	.313 [7.95]
833441625	25	.575 [14.60]	.470 [11.94]	.363 [9.22]
833451625	31	.650 [16.51]	.545 [13.84]	.438 [11.12]
833461625	37	.725 [18.41]	.620 [15.75]	.513 [13.03]
833471625	51	.900 [22.86]	.795 [20.19]	.688 [17.47]
833481625	65	1.075 [27.30]	.970 [24.64]	.863 [21.92]

3. PERFORMANCE: MEETS OR EXCEEDS M32139 PERFORMANCE SPECIFICATIONS

- CONTACT RATING: 1 AMPERE MAXIMUM
- DMV: 250 VAC
- INSULATION RESISTANCE: 5000 MEGOHMS MINIMUM @ 100 VDC
- CONTACT RESISTANCE: 0.071 VOLT MAXIMUM DROP @ 1.0 AMPS (.071 OHMS)
- W/6.00" OF WIRE LISTED BELOW, PER MIL-DTL-32139

MATERIALS: SHELL: ALUMINUM 6061-T6, ELECTROLESS NICKEL PLATED PER AMS2404

- INSULATOR: LCP (LIQUID CRYSTAL POLYMER) GLCP-30F
- CONTACT: BRASS ALLOY 735, GOLD PLATED PER ASTM B488
- LEADS: 30 AWG, NEMA HP3, TYPE ET, COLOR CODED PER MIL-DTL-681, SYSTEM 1, EXCEPT USING 10 SOLID REPEATING COLORS
- HARDWARE: 303 STAINLESS PER ASTM 582

MARKINGS: UMI, DATE CODE, UMI P/N AS SPACE PERMITS OTHERWISE ON BAG OR TAG

NOTES: UNLESS OTHERWISE SPECIFIED

QUALITY SYMBOLS	UNLESS SPECIFIED, ALL DIMENSIONS IN INCHES	SCALE	DWG SIZE	THIRD ANGLE PROJECTION	REVISE ON CAD ONLY
MAJOR =	GENERAL TOLERANCES:	DRAWN BY & DATE	B		
CRITICAL C/ =	3 PLACE ±.005	CHECKED BY & DATE	UMI 01-07-15	TITLE	NANO-D DUAL ROW CONNECTOR
SPC S/ =	2 PLACE ±.010	APPROVED BY & DATE		MATERIAL	FEMALE, SIZE XX, NMLXX-2S05-30F6-18.0 S01
	ANGULAR ±2°	SEE ECN			
		CAD FILENAME	SD-8334461625.DWG	PART NO.	
				DRAWING NO.	SD-833461625
		THIS DRAWING CONTAINS INFORMATION THAT IS PROPRIETARY TO ULTI-MATE		SHEET NO.	1 OF 1
		INCORPORATED AND SHOULD NOT BE USED WITHOUT WRITTEN PERMISSION		REV	-

UNTI-MATE CAGE CODE 58967