

PART DWG REV ISSUE	DATE	ECN NO.	APP'D BY	REL BY
-	08/26/15	UMI5732	T-POW/BART	PER

WIRING COLOR CODE

- 1, 11, 21, 31 — BLACK
- 2, 12, 22, 32 — BROWN
- 3, 13, 23, 33 — RED
- 4, 14, 24, 34 — ORANGE
- 5, 15, 25, 35 — YELLOW
- 6, 16, 26, 36 — GREEN
- 7, 17, 27, 37 — BLUE
- 8, 18, 28 — VIOLET
- 9, 19, 29 — GRAY
- 10, 20, 30 — WHITE

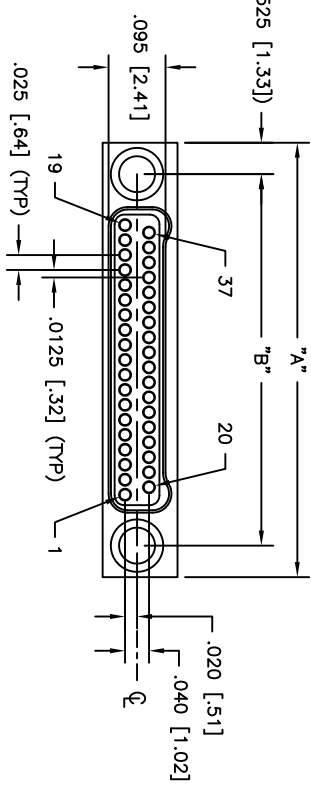
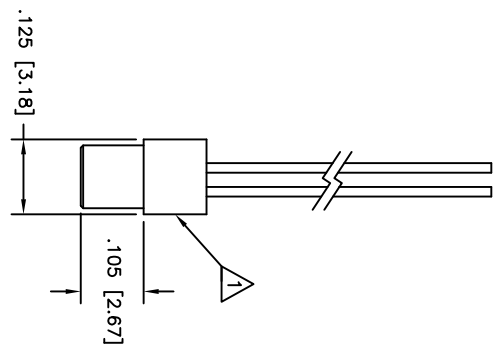
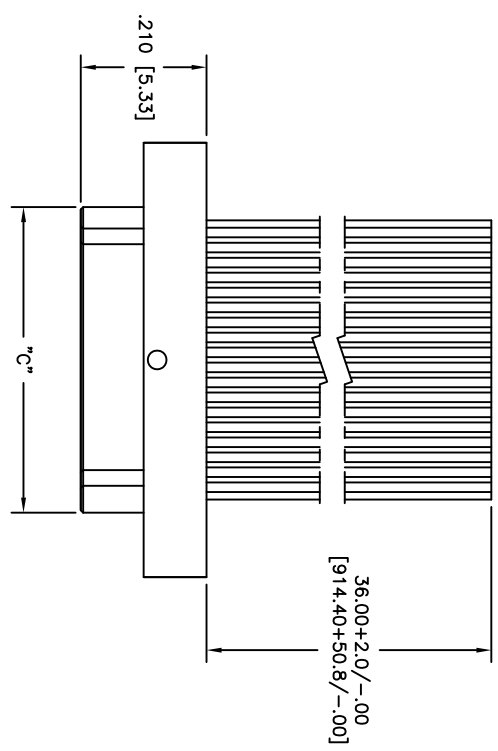

PART NO.	SIZE	"A"	"B"	"C"
833311630	9	.375 [9.52]	.270 [6.86]	.160 [4.06]
833321630	15	.450 [11.43]	.345 [8.76]	.235 [5.97]
833331630	21	.525 [13.33]	.420 [10.67]	.310 [7.87]
833341630	25	.575 [14.60]	.470 [11.94]	.360 [9.14]
833351630	31	.650 [16.51]	.545 [13.84]	.435 [11.05]
833361630	37	.725 [18.41]	.620 [15.75]	.510 [12.95]
833371630	51	.900 [22.86]	.795 [20.19]	.685 [17.40]
833381630	65	1.075 [27.30]	.970 [24.64]	.860 [21.84]

3. PERFORMANCE: MEETS OR EXCEEDS M32139 PERFORMANCE SPECIFICATIONS
 CONTACT RATING: 1 AMPERE MAXIMUM
 DMV: 250 VAC
 INSULATION RESISTANCE: 5000 MEGOHMS MINIMUM @ 100 VDC
 CONTACT RESISTANCE: 0.071 VOLT MAXIMUM DROP @ 1.0 AMPS (.071 OHMS)
 W/6.00" OF WIRE LISTED BELOW, PER MIL-DTL-32139

2. MATERIALS: SHELL: ALUMINUM 6061-T6, ELECTROLESS NICKEL PLATED PER AMS2404
 INSULATOR: LCP (LIQUID CRYSTAL POLYMER) GLCP-30F
 CONTACT: BERYLLIUM COPPER PER ASTM B194, GOLD PLATED PER ASTM B488
 LEADS: 30 AWG, NEMA HP3, TYPE ET, COLOR CODED PER MIL-DTL-681, SYSTEM 1,
 EXCEPT USING 10 SOLID REPEATING COLORS

1. MARKINGS: UMI, DATE CODE, UMI P/N AS SPACE PERMITS, OTHERWISE BAG OR TAG
 NOTES: UNLESS OTHERWISE SPECIFIED

QUALITY SYMBOLS	UNLESS SPECIFIED, ALL DIMENSIONS IN INCHES	SCALE	DWG SIZE	THIRD ANGLE PROJECTION	REVISE ON CAD ONLY
MAJOR =	GENERAL TOLERANCES:	5:1	B		
CRITICAL =	3 PLACE ±.005	DRAWN BY & DATE	08-20-15	TITLE	NANO-D DUAL ROW CONNECTOR
C =	2 PLACE ±.010	CHECKED BY & DATE		MATERIAL	MALE, SIZE XX, NMLXX-2PO-30F6-36.0 S01
SPC =	ANGULAR ±2°	APPROVED BY & DATE			
S =		SEE ECN			
		CAD FILENAME	SD-833361630.DWG	PART NO.	DRAWING NO.
		Uti+MATE CAGE CODE	58967	SEE "TAB BLOCK"	SD-833361630
		THIS DRAWING CONTAINS INFORMATION THAT IS PROPRIETARY TO UTI+MATE INCORPORATED AND SHOULD NOT BE USED WITHOUT WRITTEN PERMISSION			
				SHEET NO.	1 OF 1
				REV	-