

PART REV	DWG ISSUE	DATE	ECN NO.	APPVD BY	REL BY
-	-	7-9-14	UMI 4000	DW	DW
A	A	2-21-21	UMI 7678	DW	DW

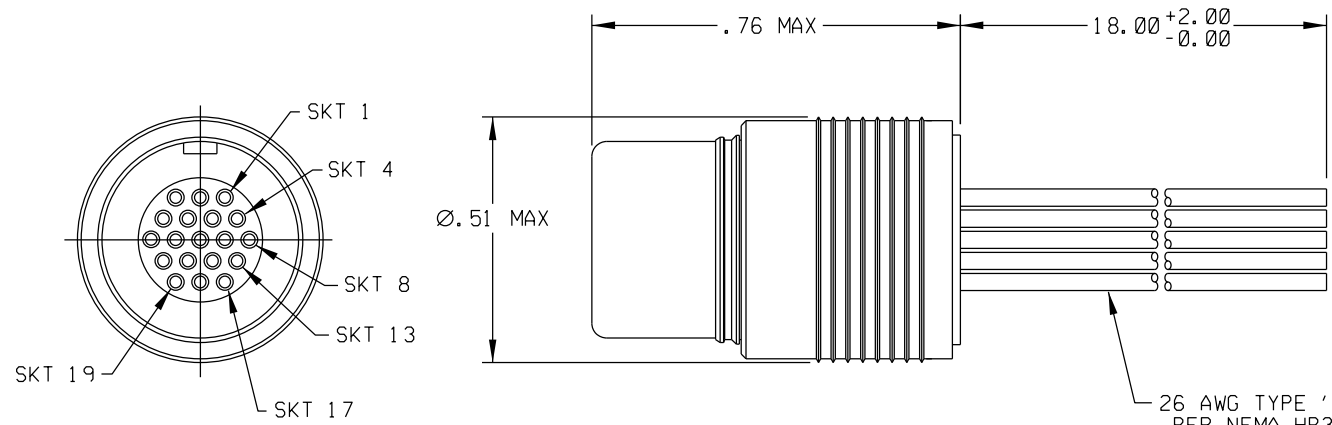

WIRING

- 1 ——— BLK
- 2 ——— BRN
- 3 ——— RED
- 4 ——— ORG
- 5 ——— YEL
- 6 ——— GRN
- 7 ——— BLU
- 8 ——— VIO
- 9 ——— GRY
- 10 ——— WHT
- 11 ——— WHT/BLK
- 12 ——— WHT/BRN
- 13 ——— WHT/RED
- 14 ——— WHT/ORG
- 15 ——— WHT/YEL
- 16 ——— WHT/GRN
- 17 ——— WHT/BLU
- 18 ——— WHT/VIO
- 19 ——— WHT/GRY

26 AWG TYPE 'E' WIRE
PER NEMA HP3-EXBDB
19 PLACES

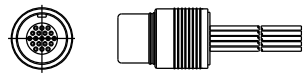

FULL SIZE

3. PERFORMANCE SPECIFICATIONS:
CURRENT RATING: 3 AMPS MAX.
INSULATION RESISTANCE: 5000 MEGOHMS MIN.
DWV: 600 VAC;
TEMPERATURE RATING: 125°C
- MATERIALS:
SHELL AND COUPLING RING: C36000 BRASS PER ASTM B16,
NICKEL PLATED PER AMS 2404
INSULATOR: PPS PER MIL-M-24519 GST-40F, COLOR: BLACK
SOCKET CONTACTS: C21000 COPPER ALLOY, GOLD PLATED PER ASTM B488
1. MARKING: NONE.

NOTES: UNLESS OTHERWISE SPECIFIED.

QUALITY SYMBOLS CRITICAL SPECIAL KEY	UNLESS SPECIFIED: ALL DIMENSIONS IN INCHES GENERAL TOLERANCES: 3 PLACE ±.005 2 PLACE ±.01 ANGULAR ±2°	SCALE: NONE DWG SIZE: B THIRD ANGLE PROJECTION	REVISE ON CAD ONLY		
	ALL EXTERNAL SPECIFICATIONS REFERENCED ON THIS DRAWING SHALL BE TO THE LATEST REVISION IN EFFECT Ulti-Mate CAGE CODE 58967	DRAWN BY & DATE: DW 6-17-11 CHECKED BY & DATE: SEE ECN APPROVED BY & DATE: SEE ECN	TITLE: RQ SERIES PLUG, FEMALE CONTACTS, SIZE 2 SHELL, 19 POSITION, RQP0B2-19S-26E5-18.0 SPL MATERIAL:		SHEET NO. 1 OF 1 PART REV A
		CAD FILENAME: SD-831021050.DGN PART NO.: 831021050 DRAWING NO.: SD-831021050	Ulti-Mate Connector Inc.		
	THIS DRAWING CONTAINS INFORMATION THAT IS PROPRIETARY TO ULTI-MATE INCORPORATED AND SHOULD NOT BE USED WITHOUT WRITTEN PERMISSION.				