

WIRING COLOR CODE

1	BLACK
2	BROWN
3	RED
4	ORANGE
5	YELLOW
6	GREEN
7	BLUE

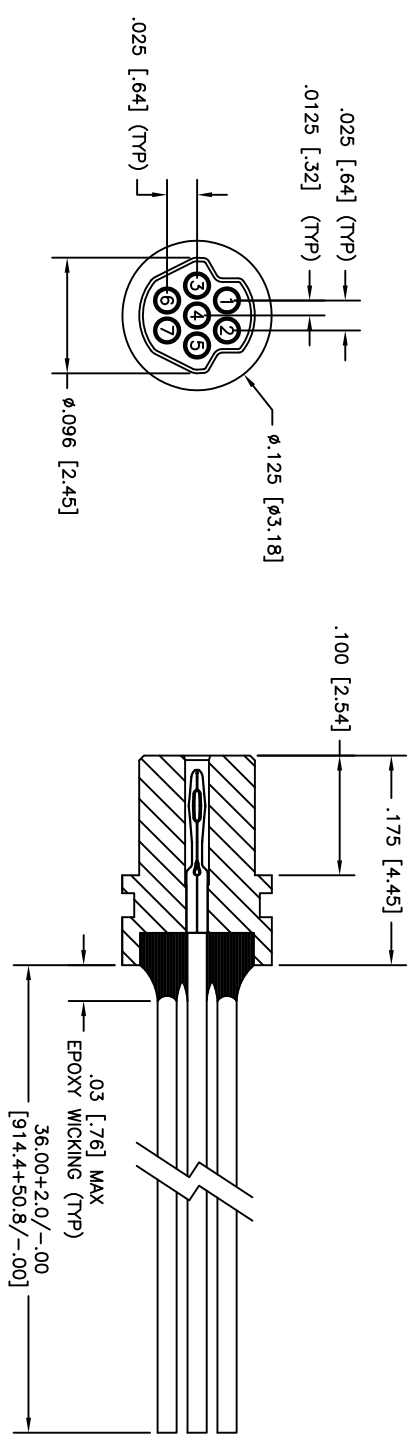

- 3. PERFORMANCE: MEETS OR EXCEEDS M32139 PERFORMANCE SPECIFICATIONS**
- CONTACT RATING: 1 AMPERE MAXIMUM
  - INSULATION RESISTANCE: 5000 MEGOHMS MINIMUM @ 100 VDC
  - DMV: 250 VAC
  - CONTACT RESISTANCE: 0.071 VOLT MAXIMUM DROP @ 1.0 AMPS (.071 OHMS)
  - W/6.00" OF WIRE LISTED BELOW, PER MIL-DTL-32139
- 1. MARKINGS: UMI, UMI P/N, DATE CODE & W/O NO. ON BAG OR TAG**
- NOTES: UNLESS OTHERWISE SPECIFIED

QUALITY SYMBOLS MAJOR = CRITICAL = SPC = S =	UNLESS SPECIFIED, ALL DIMENSIONS IN INCHES GENERAL TOLERANCES: 3 PLACE ±.005 2 PLACE ±.010 ANGULAR ±2°	SCALE 10:1 DWG SIZE B DRAWN BY & DATE PER 04-12-19 CHECKED BY & DATE APPROVED BY & DATE SEE ECN	THIRD ANGLE PROJECTION TITLE: NANO CIRCULAR CONNECTOR, SIZE 7 PLUG, RNPDP-07P-30F6-36.0	REVISE ON CAD ONLY
	CAD FILENAME: SD-821031130.DWG PART NO.: 821031130 DRAWING NO.: SD-821031130 SHEET NO.: 1 OF 1 PART REV: -	Uti-Mate CAGE CODE 58967	THIS DRAWING CONTAINS INFORMATION THAT IS PROPRIETARY TO UTI-MATE INCORPORATED AND SHOULD NOT BE USED WITHOUT WRITTEN PERMISSION.	Uti-Mate Connector Inc.

PART DWG	DATE	ECN NO.	APPVD BY	REL BY
REV ISSUE	04/12/19	UMI7115	TPOMBART	PER