

WIRING COLOR CODE

- 1 — BLACK
- 2 — BROWN
- 3 — RED
- 4 — ORANGE
- 5 — YELLOW
- 6 — GREEN
- 7 — BLUE

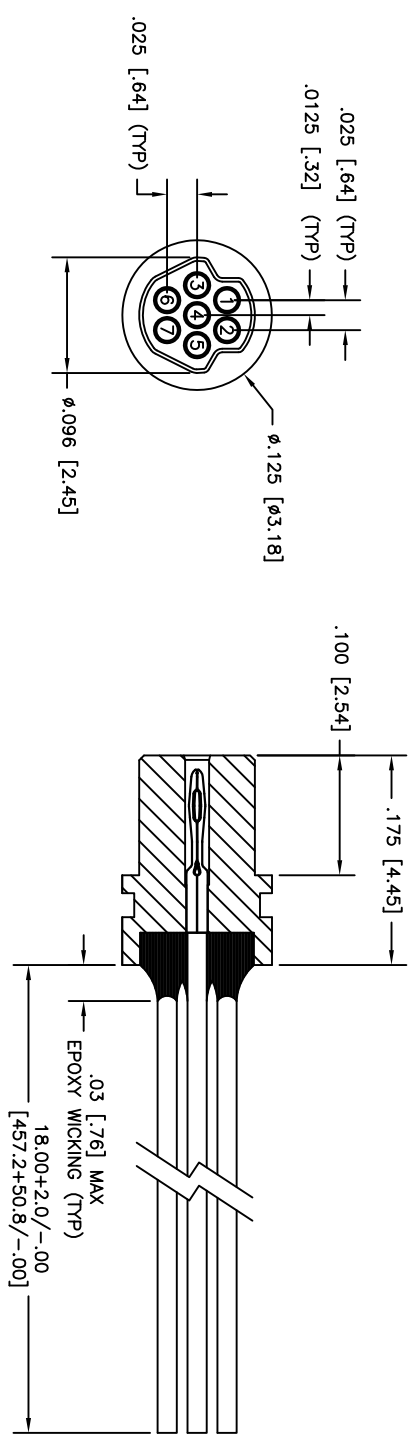

3. PERFORMANCE: MEETS OR EXCEEDS M32139 PERFORMANCE SPECIFICATIONS

CONTACT RATING: 1 AMPERE MAXIMUM
 INSULATION RESISTANCE: 5000 MEGOHMS MINIMUM @ 100 VDC
 DMV: 250 VAC
 CONTACT RESISTANCE: 0.071 VOLT MAXIMUM DROP @ 1.0 AMPS (.071 OHMS)
 W/6.00° OF WIRE LISTED BELOW, PER MIL-DTL-32139

MATERIALS: INSULATOR: LCP (LIQUID CRYSTAL POLYMER) GLCP-30F
 CONTACTS: BERYLLIUM COPPER PER ASTM B194, GOLD PLATED PER ASTM B488
 LEADS: 30 AWG, NEMA HP3, TYPE ET, COLOR CODED PER MIL-DTL-681, SYSTEM 1

1. MARKINGS: UMI, UMI P/N, DATE CODE & W/O NO. ON BAG OR TAG
 NOTES: UNLESS OTHERWISE SPECIFIED

PART DWG	DATE	ECN NO.	APP'D BY	REL BY
REV				
ISSUE	01/31/17	UMI6217	TPOBART	PER

QUALITY SYMBOLS	UNLESS SPECIFIED, ALL DIMENSIONS IN INCHES	SCALE	DWG SIZE	THIRD ANGLE PROJECTION	REVISE ON CAD ONLY
MAJOR =	GENERAL TOLERANCES:	10:1	B		
CRITICAL =	3 PLACE ±.005	DRAWN BY & DATE	PER	TITLE:	
C =	2 PLACE ±.010	12-23-14	SEE ECN	NANO CIRCULAR CONNECTOR, SIZE 7	
	ANGULAR ±2°	CHECKED BY & DATE	SEE ECN	PLUG, RNPDP-07P-30F6-18.0	
SPC =		APPROVED BY & DATE	SEE ECN	MATERIAL:	
U =		CAD FILENAME			
		SD-821031120.DWG	PART NO.	821031120	DRAWING NO.
		Uti+MATE CAGE CODE		SD-821031120	SHEET NO.
		58967			1 OF 1
					REV
					-

THIS DRAWING CONTAINS INFORMATION THAT IS PROPRIETARY TO UTI-MATE INCORPORATED AND SHOULD NOT BE USED WITHOUT WRITTEN PERMISSION.