

WIRING COLOR CODE

- 1 — BLACK
- 2 — BROWN
- 3 — RED
- 4 — ORANGE
- 5 — YELLOW
- 6 — GREEN
- 7 — BLUE
- 8 — VIOLET
- 9 — GRAY

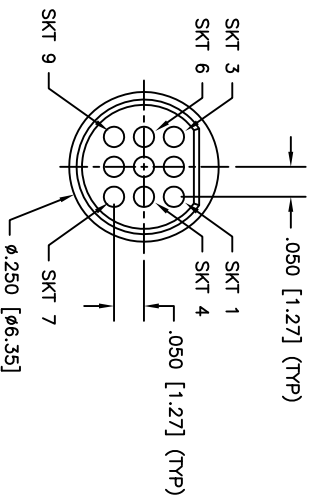
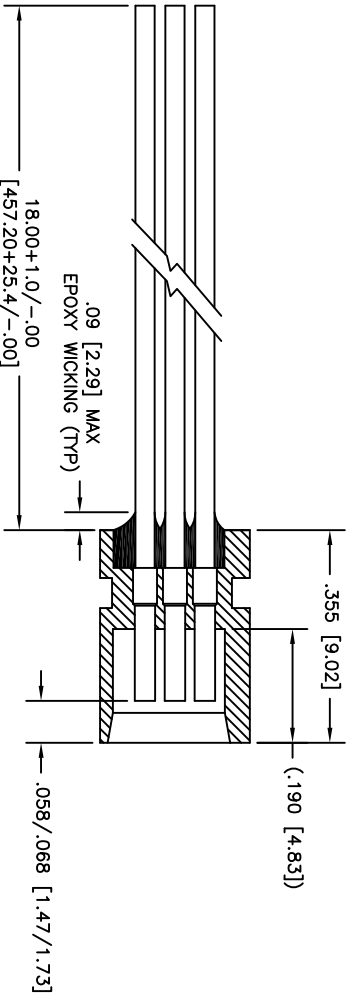

3. PERFORMANCE: MEETS OR EXCEEDS M83513 PERFORMANCE SPECIFICATIONS
 CONTACT RATING: 3 AMPERE MAXIMUM
 INSULATION RESISTANCE: 5000 MEGOHMS MINIMUM @ 500 VDC
 CONTACT RESISTANCE: 8 MILLIOHMS MAX @ 2.5 AMPS

2. MATERIALS: INSULATOR: PPS PER MIL-M-24519 GST-40F, OR LCP (LIQUID CRYSTAL POLYMER)
 GLOP-30F COLOR: BLACK
 CONTACTS: BRASS ALLOY 210, GOLD PLATED PER ASTM B488
 LEADS: 26 AWG, MIL-W-16878/4, COLOR CODED

1. MARKINGS: UMI, UMI P/N, DATE CODE & W/O NO. ON BAG OR TAG

NOTES: UNLESS OTHERWISE SPECIFIED

QUALITY SYMBOLS MAJOR = CRITICAL =	UNLESS SPECIFIED, ALL DIMENSIONS IN INCHES GENERAL TOLERANCES: 3 PLACE ±.005 2 PLACE ±.010 ANGULAR ±2°	SCALE 10:1	DWG SIZE B	THIRD ANGLE PROJECTION	REVISE ON CAD ONLY
SPC =	Uti+Mate CASE CODE 58967	DRAWN BY & DATE PER 05-13-19	TITLE MICRO CIRCULAR CONNECTOR, FEMALE (RECEPTACLE), SIZE 9, RPOP-09S-26E6-18.0	CAD FILENAME SD-812071120.DWG	PART NO. 812071120
		CHECKED BY & DATE SEE ECN	MATERIAL 	APPROVED BY & DATE SEE ECN	DRAWING NO. SD-812071120
					SHEET NO. 1 OF 1
					PART REV -

PART DWG REV ISSUE	DATE	ECN NO.	APPRD BY	REL BY
-	05/13/19	UMI7146	TPOWBART	PER