

PART DWG		DATE		ECN NO.		APP'D BY		REL BY	
REV	ISSUE	DATE	DATE	NO.	NO.	NAME	NAME	NAME	NAME
A	A	05-05-17		UM6339		T.POMBART		PER	
A	B	07-13-17		UM6434		T.POMBART		PER	

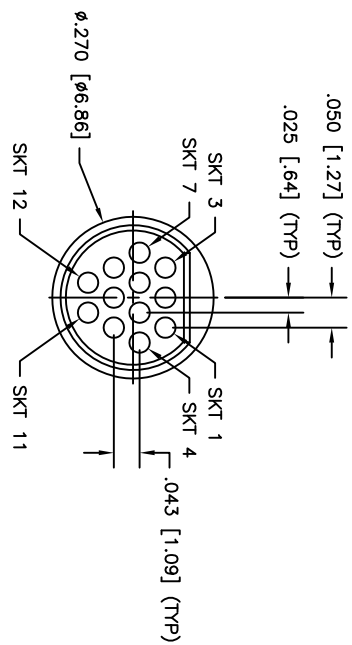
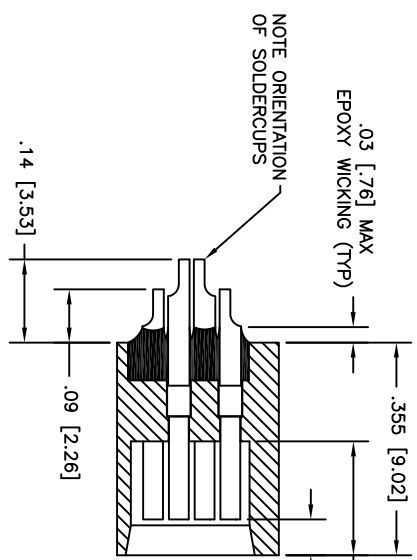

3. PERFORMANCE: MEETS OR EXCEEDS M83513 PERFORMANCE SPECIFICATIONS  
 CONTACT RATING: 3 AMPERE MAXIMUM  
 INSULATION RESISTANCE: 5000 MEGOHMS MINIMUM @ 500 VDC  
 CONTACT RESISTANCE: 8 MILLIOHMS MAX @ 2.5 AMPS

2. MATERIALS: INSULATOR: PPS PER MIL-M-24519 GST-40F, OR LCP (LIQUID CRYSTAL POLYMER)  
 GLCP-30F COLOR: BLACK  
 CONTACTS: BRASS ALLOY 314, GOLD PLATED PER ASTM B488

1. MARKINGS: UMI, UMI P/N, DATE CODE & W/O NO. ON BAG OR TAG  
 NOTES: UNLESS OTHERWISE SPECIFIED

QUALITY SYMBOLS	UNLESS SPECIFIED, ALL DIMENSIONS IN INCHES	SCALE	DWG SIZE	THIRD ANGLE PROJECTION	REVISE ON CAD ONLY
MAJOR =	GENERAL TOLERANCES:	DRAWN BY & DATE	B		
CRITICAL =	3 PLACE ±.005	PER 02-09-17			
SPC =	2 PLACE ±.010	CHECKED BY & DATE			
S =	ANGULAR ±2°	SEE ECN			
		APPROVED BY & DATE			
		SEE ECN			
		CAD FILENAME			
		E-812041000.DWG			
		PART NO.	812041000		
		DRAWING NO.	E-812041000		
		Uti-Mate Connector Inc.			
		SHEET NO.	1 OF 1		
		PART REV	A		