

PART REV	DWG ISSUE	DATE	ECN NO.	APPVD BY	REL BY
-	-	11/15/17	UMI6562	DW	DW

F
E
D
C
B
A

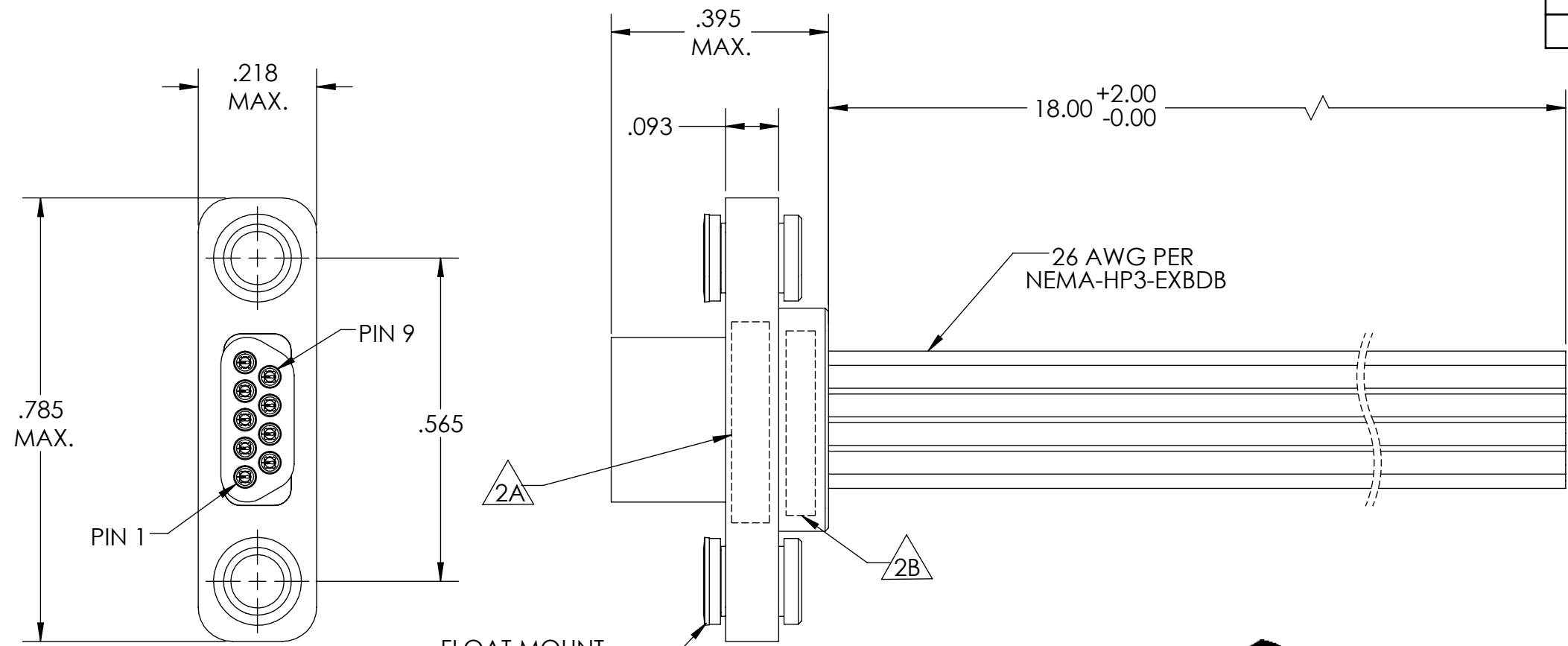

1	BLK
2	BRN
3	RED
4	ORG
5	YEL
6	GRN
7	BLU
8	VIO
9	GRY

FLOAT MOUNT
 ϕ .096 MAX. THRU
 ALLOWABLE DIAMETRAL FLOAT .014 \pm .004
 ALLOWABLE AXIAL FLOAT .020 MAX.
 2X

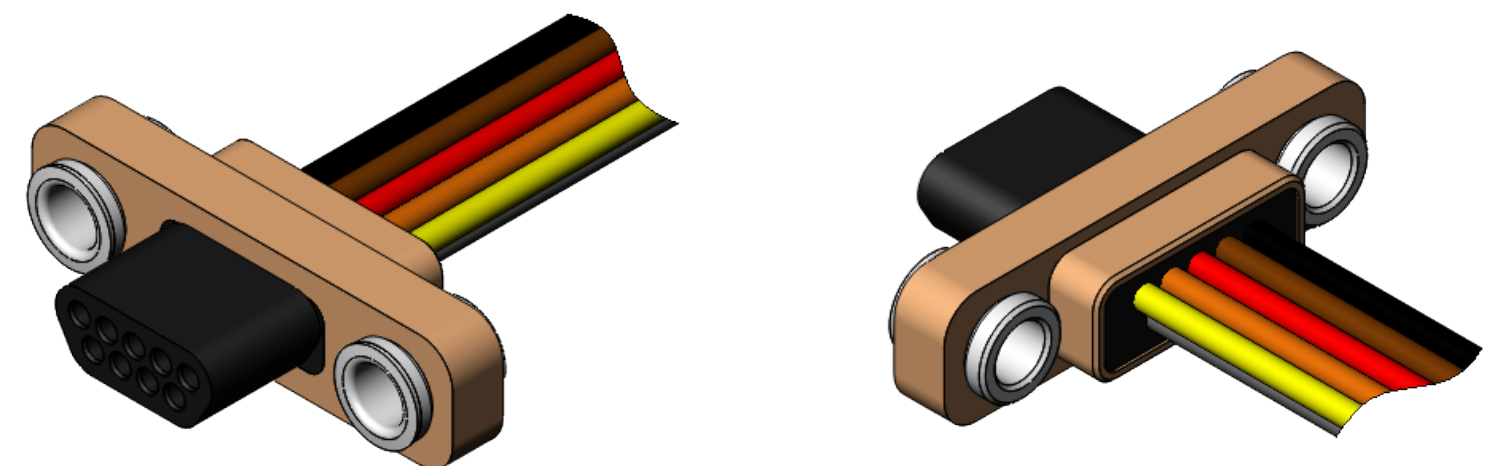

- 5. CONTACT HEIGHTS ARE TO BE PER QA-STD-101.
- 4. PERFORMANCE SPECIFICATIONS (AT AMBIENT TEMPERATURE):
 CURRENT RATING: 3 AMPS MAX.
 INSULATION RESISTANCE: 5000 MEGOHMS MIN.
 DWV: 600 VAC
 TEMPERATURE RATING: 200° C

3 MATERIALS:
 SHELL: 6061-T6 ALUMINUM PER AMS-QQ-A200/8, CADMIUM PLATED PER AMS-QQ-P-416
 INSULATOR: PPS PER MIL-M-24519 GST-40F, COLOR: BLACK
 PIN CONTACT: C17410 BERYLLIUM COPPER PER ASTM B768, GOLD PLATED PER ASTM B488
 WIRE: 26 AWG PER NEMA-HP3-EXBDB, COLOR CODE PER MIL-STD-681
 HARDWARE: PASSIVATED STAINLESS STEEL, 300 SERIES

- 2. MARKING:
 2A "UMI", DATE CODE, UMI PART NUMBER
 2B UMI WORK ORDER NUMBER

1. CONNECTOR ASSEMBLY IS IAW MIL-DTL-83513 UNLESS OTHERWISE SPECIFIED.
NOTES: UNLESS OTHERWISE SPECIFIED.

QUALITY SYMBOLS CRITICAL MAJOR NO SYMBOLS = MINOR DIMENSIONS	UNLESS OTHERWISE SPECIFIED: ALL DIMENSIONS ARE IN INCHES	SCALE 4:1	DWG SIZE B	THIRD ANGLE PROJECTION	REVISE ON CAD ONLY	
	GENERAL TOLERANCES: 3 PLACES \pm .005 2 PLACES \pm .01 ANGULAR \pm 2°	DRAWN BY & DATE DU 11/15/17	TITLE: MICRO-D CONNECTOR ASSEMBLY, LOW-PROFILE, APR09P0-26E5-18.0-F01-HT		MATERIAL: 3	
	ULTI-MATE CAGE CODE 58967	CHECKED BY & DATE DW 11/15/17	PART NO. 434310071		ENG PROJECT #: NONE	 Ulti-Mate Connector Inc.
		APPROVED BY & DATE DW 11/15/17	DRAWING NO. SD-434310071		SHEET NO. 1 of 1	
		CAD FILE NAME SD-434310071.SLDDRW	PART NO. 434310071		THIS DRAWING CONTAINS INFORMATION THAT IS PROPRIETARY TO ULTI-MATE INCORPORATED AND SHOULD NOT BE USED WITHOUT WRITTEN PERMISSION.	