

PART DWG REV ISSUE	DATE	ECN NO.	APP'D BY	REL BY
-	07/10/14	UMI5365	T-POWERT	PER

WIRING COLOR CODE

- 1, 11, 21, 31 — BLACK
- 2, 12, 22, 32 — BROWN
- 3, 13, 23, 33 — RED
- 4, 14, 24, 34 — ORANGE
- 5, 15, 25, 35 — YELLOW
- 6, 16, 26, 36 — GREEN
- 7, 17, 27, 37 — BLUE
- 8, 18, 28 — VIOLET
- 9, 19, 29 — GRAY
- 10, 20, 30 — WHITE

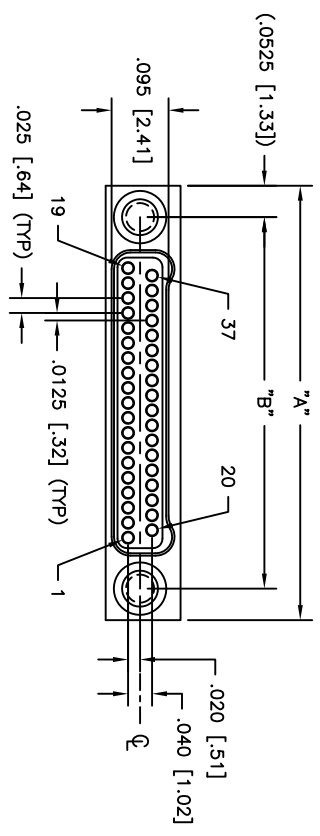
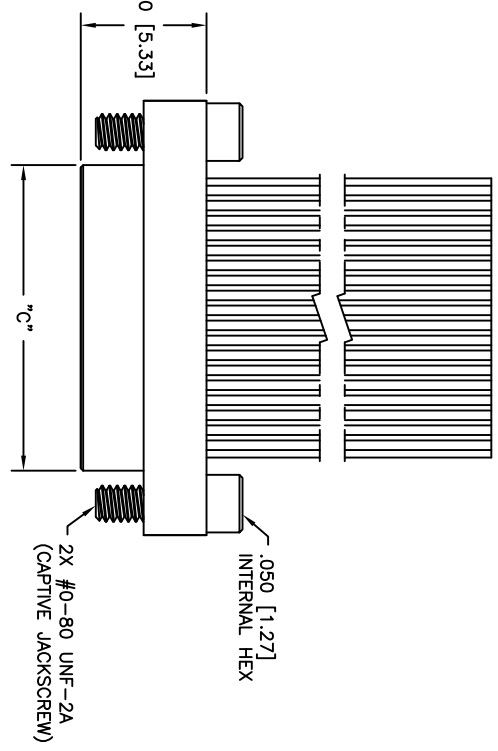

PART NO.	SIZE	"A"	"B"	"C"
433313632	9	.375 [9.52]	.270 [6.86]	.160 [4.06]
433323632	15	.450 [11.43]	.345 [8.76]	.235 [5.97]
433333632	21	.525 [13.33]	.420 [10.67]	.310 [7.87]
433343632	25	.575 [14.60]	.470 [11.94]	.360 [9.14]
433353632	31	.650 [16.51]	.545 [13.84]	.435 [11.05]
433363632	37	.725 [18.41]	.620 [15.75]	.510 [12.95]
433373632	51	.900 [22.86]	.795 [20.19]	.685 [17.40]
433383632	65	1.075 [27.30]	.970 [24.64]	.860 [21.84]

- PERFORMANCE: MEETS OR EXCEEDS M32139 PERFORMANCE SPECIFICATIONS  
 CONTACT RATING: 1 AMPERE MAXIMUM AT AMBIENT TEMPERATURE  
 INSULATION RESISTANCE: 5000 MEGOHMS MINIMUM @ 100 VDC  
 CONTACT RESISTANCE: 0.071 VOLT MAXIMUM DROP @ 1.0 AMPS (.071 OHMS)  
 W/6.00" OF WIRE LISTED BELOW, PER MIL-DTL-32139
- MATERIALS: SHELL: ALUMINUM 6061-T6, ANODIZE PER MIL-A-8625, TYPE III, CLASS 2, BLACK  
 INSULATOR: LCP (LIQUID CRYSTAL POLYMER) GLOP-30F  
 CONTACT: BERYLLIUM COPPER PER ASTM B194, GOLD PLATED PER ASTM B488  
 LEADS: 30 AWG, NEMA HP3, TYPE ET, COLOR CODED PER MIL-DTL-681, SYSTEM 1,  
 EXCEPT USING 10 SOLID REPEATING COLORS, 36.0" +0.5/-0.0 LONG  
 HARDWARE: 303 STAINLESS PER ASTM 582  
 EPOXY: 200° CELSIUS
- MARKINGS: UMI, DATE CODE, UMI P/N AS SPACE PERMITS

QUALITY SYMBOLS  
 MAJOR =  
 CRITICAL =  
 SPC =  
 S =

UNLESS SPECIFIED, ALL DIMENSIONS IN INCHES  
 GENERAL TOLERANCES:  
 3 PLACE ±.005  
 2 PLACE ±.010  
 ANGULAR ±2°

SCALE: 5:1  
 DWG SIZE: B  
 DRAWN BY & DATE: UMI 06-05-14  
 CHECKED BY & DATE:  
 SEE ECN  
 APPROVED BY & DATE:  
 SEE ECN

CAD FILENAME: SD-433363632.DWG  
 THIS DRAWING CONTAINS INFORMATION THAT IS PROPRIETARY TO ULTIMATE INCORPORATED AND SHOULD NOT BE USED WITHOUT WRITTEN PERMISSION.

PART NO. SD-433363632  
 DRAWING NO. SD-433363632  
 SHEET NO. 1 OF 1

TITLE: NANO-D DUAL ROW CONNECTOR  
 MALE, SIZE XX, NMLXX-2P02-30F6-36.0 S03 HT  
 MATERIAL:  
 THIRD ANGLE PROJECTION  
 REVISE ON CAD ONLY

Uti-Mat Connector Inc.

NOTES: UNLESS OTHERWISE SPECIFIED