

WIRED CONNECTOR

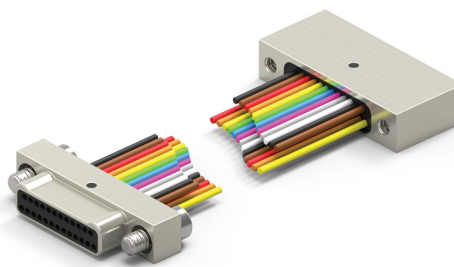













- Metal Shell Connector w/Wire Leads
- Operating Temperature -50° C to 200° C
- 9 to 65 Contacts



NANO D – PID 127

HOW TO ORDER

* Indicates preferred standard ** Consult factory for other options

N	M	L	25	-	2	P	Ø2	/NMLX-2XX	-	3Ø	F	6	-	18.Ø	-	SØ1
Series	Insulator	Contacts	Insulator Type	Contact Gender	Hardware	Detail of Other End of the Harness	Wire Gauge	Wire Type**	Color Code	Length**	Finish**	Temp Range				
N= Nano	M= Metal	L= LCP	Ø9	2= Dual Row	P=Male/Pin (Plug Side)	Ø No Hardware	Refer to the left columns for filling out the x	3Ø*	1=White	*18.Ø	Blank= Cadmium	*Blank = 125C				
			15				32	*F=Stranded, w/Teflon insulation, per NEMA HP3-ET	*6 = 10 solid colors, repeating	*36.Ø		HT = 200°C				
			21		S=Female/Socket (Receptacle Side)	Ø1=Phillips Head Jackscrew	34	Y=Stranded w/Tefzel insulation, per SAE AS22759/33			*SØ1= Nickel					
			25													
			31			*Ø2=Allen Head Jackscrew					SØ3 = Black Anodize					
			37					A=Stranded, per DSCC Ø4Ø47-3ØA (White, 3Ø AWG only)								
			51			Ø5=Slotted Head Jackscrew					SØ9= Stainless					
			65													
						Ø6=Floating Phillips Head Jackscrew (Female Only)										
																
						Ø7=Threaded Hole										
																
						Ø8=Floating Allen Head Jackscrew (Female Only)										
																
						Ø9=Floating Slotted Head Jackscrew (Female Only)										
																

DIMENSIONS

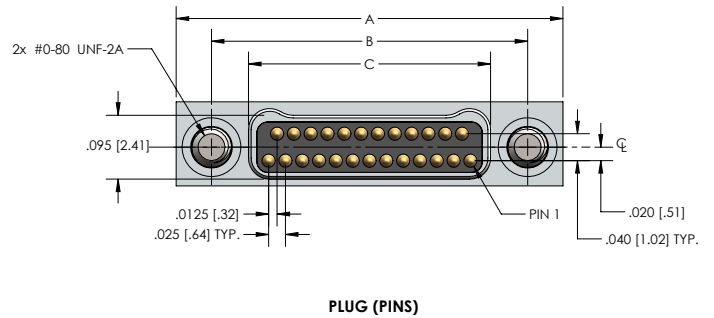
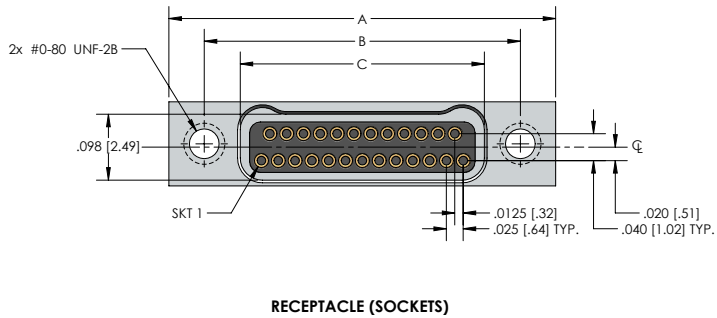
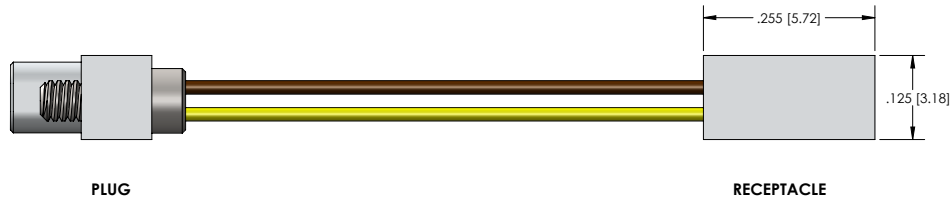
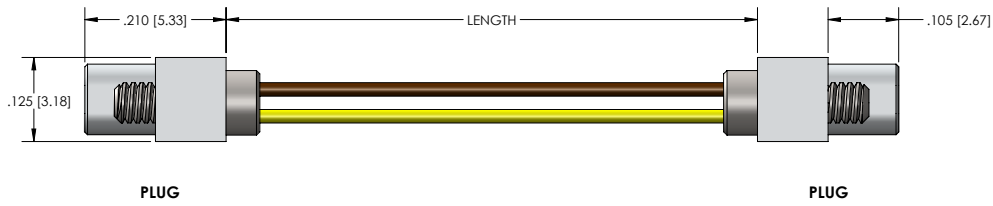

NML SERIES (DUAL ROW)					
Size	A	B	Plug	C	Receptacle
9	.375 [9.52]	.270 [6.86]	.160 [4.06]		.163 [4.14]
15	.450 [11.43]	.345 [8.76]	.235 [5.97]		.238 [6.04]
21	.525 [13.33]	.420 [10.67]	.310 [7.87]		.313 [7.95]
25	.575 [14.60]	.470 [11.94]	.360 [9.14]		.363 [9.22]
31	.650 [16.51]	.545 [13.84]	.435 [11.05]		.438 [11.12]
37	.725 [18.41]	.620 [15.75]	.510 [12.95]		.513 [13.03]
51	.900 [22.86]	.795 [20.19]	.685 [17.40]		.688 [17.47]
65	1.075 [27.30]	.970 [24.64]	.860 [21.84]		.863 [21.92]

NANO-D WIRED SERIES METAL PERFORMANCE DATA, MATERIALS AND FINISHES

PERFORMANCE DATA

123-E	ELECTRICAL
CONTACT RESISTANCE:	.080 mΩ max.@ 1.0 A
CURRENT RATING (SIGNAL CONTACTS):	1.0 A max.
DIELECTRIC WITHSTANDING VOLTAGE:	250 VAC at sea level , 100 VAC at 70,000 ft.
INSULATION RESISTANCE:	5,000 MΩ min..

123-M	MECHANICAL
CONTACT ENGAGING FORCE:	5 oz max. (Contact average is 2 oz.)
CONTACT SEPARATING FORCE:	0.4 oz. min.
CONNECTOR MATING FORCE:	7 oz. x number of contacts max.
CONNECTOR UNMATING FORCE:	7 oz. x number of contacts max.
VIBRATION:	No damage or interruption detected (one microsecond sensitivity) EIA-364-28 Condition IV
SHOCK:	No damage or interruption detected (one microsecond sensitivity) EIA-364-28 Condition IV
DURABILITY:	No mechanical or electrical defects after 200 matings.
SALT SPRAY:	No exposure of base metal or loss of performance after 96 hours for both Nickel and Cadmium plating

MATERIALS AND FINISHES

123-M&F	MATERIALS AND FINISHES
Pin Contacts	BeCu Alloy Strip per ASTM-B-194
Socket Contacts	Brass Alloy C260 per ASTM B135
Contact Plating	Gold Plate per ASTM B488, or SAE AMS 2422
Metal Shells	Aluminum Alloy per SAE-AMS-QQ-A-200/8, TYPE 6061-T6 with Electroless Nickel Plating per SAE-AMS2404, CLASS 3 OR 4 Aluminum Alloy per SAE-AMS-QQ-A-200/8, TYPE 6061-T6 with Cadmium Plating SAE-AMS-QQ-P-416, TYPE II, CLASS 1 Aluminum Alloy per SAE-AMS-QQ-A-200/8, TYPE 6061-T6 with Black Anodize Plating per MIL-A-8625, TYPE III, CLASS 2 Stainless Steel per ASTM A582
Molded Insulators Into Metal Housing	LCP (Liquid Crystal Polymer) GLCP-30F or PPS per MIL-M-24519 GST-40F
Hardware	Corrosion Resistant Steel per ASTM A 582/A582 or ASTM A 581/A581M, Passivated per SAE AMS-2700