

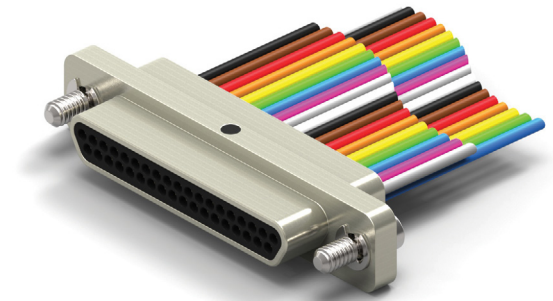

















WIRED CONNECTOR

- Standard Profile Metal Shell Connector w/Wire Leads
- Environmentally Sealed
- Operating Temperature -50° C to 200° C
- 9 to 100 Contacts



HOW TO ORDER

* Indicates preferred standard, ** consult factory for other plating options, *** Leave blank if no Mounting Option is required (F01-Float Mount is not available for size 100)

M	R	51-3	P	Ø2 - 26	E	6 - 18.0 - SØ1					
Series	Insulator	Contacts**	Contact Gender	Hardware	Wire Gauge	Wire Type **	Color Code	Length**	Finish**	Temp Range	Mounting Option**
M= Metal	R=PPS	Ø9	P=Male/Pin (Plug Side)	Ø No Hardware	24	C = Solid Wire, Uninsulated	1 = White	*18.0	Blank= Cadmium	*Blank = 125C	F01- Float Mount
		15			25		2 = Yellow	*36.0		HT = 200C	
		21	S=Female/Socket (Receptacle Side)	*Ø2 (12 for Size 100) 22 (Swaged) Allen Head Jackscrew	26*	*E = Stranded w/Teflon Insulation, per NEMA HP3-EX	3 = Tin Plated (Solid Wire)		*SØ1 = Nickel		
		25			28		4 = Gold Plated (Solid Wire)				
		31		Ø3 (13 for Size 100) High Profile Allen Head Jackscrew	3Ø	F = Stranded, w/Teflon Insulation, per NEMA HP3-ET	5 = Color Code per MIL-STD-681 (Non-Repeating Colors)		SØ3 = Black Anodize		
		37					*6 = 1Ø Solid Colors, Repeating				
				*Ø5 (15 for Size 100) Slotted Head Jackscrew		M = Stranded, w/Teflon Insulation, per SAE-AS22759/11			SØ6 = Olive-Drab Cadmium		
		51-3									
				Ø6 (16 for Size 100) High Profile Slotted Head Jackscrew		Y = Stranded w/Tefzel Insulation, per SAE-AS22759/33			SØ7 = Titanium		
		100									
				Ø7 (17 for Size 100) Jack post					SØ9 = Stainless		
											

DIMENSIONS

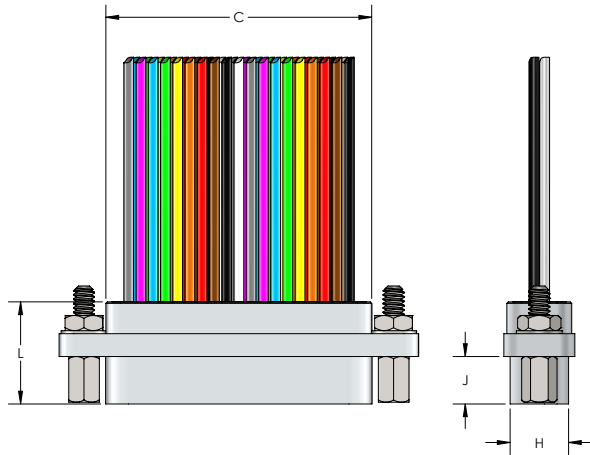

RECEPTACLE (SOCKETS)

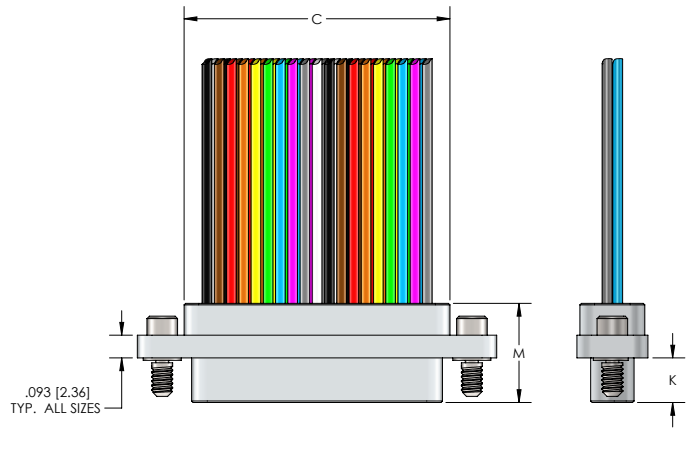

PLUG (PINS)

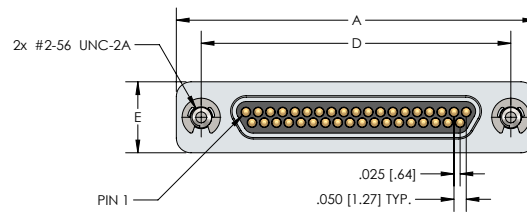
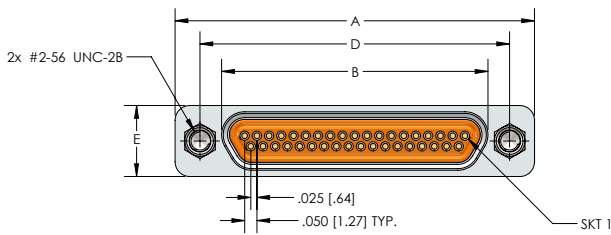

Size	ALL					M SERIES				
	A Max.	B Max.	C Max.	D Max.	E Max.	H Max.	J Max. (Skt)	K Max. (Pin)	L Max. (Skt)	M Max. (Pin)
9	.785 (19.94)	.402 (10.21)	.393 (9.98)	.565 (14.35)	.308 (7.83)	.248 (6.30)	.199 (5.05)	.187 (4.75)	.429 (10.90)	.416 (10.57)
15	.935 (23.75)	.552 (14.02)	.543 (13.79)	.715 (18.16)	.308 (7.83)	.248 (6.30)	.199 (5.05)	.187 (4.75)	.429 (10.90)	.416 (10.57)
21	1.085 (27.56)	.702 (17.83)	.693 (17.60)	.865 (21.47)	.308 (7.83)	.248 (6.30)	.199 (5.05)	.187 (4.75)	.429 (10.90)	.416 (10.57)
25	1.185 (30.10)	.802 (20.37)	.793 (20.14)	.965 (24.51)	.308 (7.83)	.248 (6.30)	.199 (5.05)	.187 (4.75)	.429 (10.90)	.416 (10.57)
31	1.335 (33.91)	.952 (24.18)	.943 (23.95)	1.115 (28.32)	.308 (7.83)	.248 (6.30)	.199 (5.05)	.187 (4.75)	.429 (10.90)	.416 (10.57)
37	1.485 (37.72)	1.102 (27.99)	1.093 (27.76)	1.265 (32.13)	.308 (7.83)	.248 (6.30)	.199 (5.05)	.187 (4.75)	.429 (10.90)	.416 (10.57)
51-3	1.435 (36.45)	1.054 (26.77)	1.041 (26.44)	1.215 (30.86)	.351 (8.92)	.297 (7.54)	.199 (5.05)	.187 (4.75)	.429 (10.90)	.416 (10.57)
100	2.165 (54.99)	1.505 (38.23)	1.442 (36.63)	1.800 (45.72)	.394 (10.00)	.394 (10.00)	.199 (5.05)	.187 (4.75)	.429 (10.90)	.416 (10.57)

MICRO-D WIRED SERIES METAL PERFORMANCE DATA, MATERIALS AND FINISHES

PERFORMANCE DATA

10-E	ELECTRICAL
CONTACT RESISTANCE:	8 mΩ max. @ 2.5 A
CURRENT RATING (SIGNAL CONTACTS):	3 A max.
DIELECTRIC WITHSTANDING VOLTAGE:	900 VAC at sea level, 300 VAC at 70,000 ft.
INSULATION RESISTANCE:	5,000 MΩ min.

10-M	MECHANICAL
CONTACT ENGAGING FORCE:	6 oz max. (Contact average is 3 oz.)
CONTACT SEPARATING FORCE:	0.5 oz. min.
CONNECTOR MATING FORCE:	10 oz. x number of contacts max.
CONNECTOR UNMATING FORCE:	10 oz. x number of contacts min.
VIBRATION:	No damage or interruption detected (one microsecond sensitivity) EIA-364-28 Condition IV
SHOCK:	No damage or interruption detected (one microsecond sensitivity) EIA-364-27 Condition E
DURABILITY:	No mechanical or electrical defects after 500 matings.
SALT SPRAY:	No exposure of base metal or loss of performance after 96 hours for both Nickel and Cadmium plating

MATERIALS AND FINISHES

10-M&F	MATERIALS AND FINISHES
Pin Contacts	Beryllium Copper (C17200) per ASTM B194.
Socket Contacts	Copper alloy (C21000) per ASTM B36
Contact Plating	Gold plated per ASTM-B488. 50 microinches min. is the standard thickness.
Metal Shells	Aluminum alloy per SAE-AMS-QQ-A-200/8, type 6061-T6. Finish is cadmium per SAE-AMS-QQ-P-416, TYPE II, CLASS 3, with suitable underplate with yellow chromate, this plating is not RoHS compliant. Or Finish Electroless Nickel plate per SAE AMS2404, class 3 or 4, .0005 minimum thickness. (RoHS compliant). For other finishes detail consult factory.
Insulator Material Shell	Polyphenylene sulfide (PPS) per MIL-M-24519 GST 40F or ASTM D5927. Color Black.
Interfacial Seals	Fluorosilicone elastomer per MIL-R-25988. Standard on "M" Series socket face.
Hardware	Corrosion resistant steel per ASTM A 582/A582 or ASTM A 581/A581M, Passivated per SAE AMS-2700
O-Ring For Front & Rear Panel Series	Non Conductive: Fluorosilicone or Silicone Conductive: Conductive Fluorosilicone